



Standard Test Method for In-Plane Shear Properties of Polymer Matrix Composite Materials by the Rail Shear Method¹

This standard is issued under the fixed designation D 4255/D 4255M; the number immediately following the designation indicates the year of original adoption or, in the case of revision, the year of last revision. A number in parentheses indicates the year of last reapproval. A superscript epsilon (ϵ) indicates an editorial change since the last revision or reapproval.

This standard has been approved for use by agencies of the Department of Defense.

1. Scope

1.1 This test method determines the in-plane shear properties of high-modulus fiber-reinforced composite materials by either of two procedures. In Procedure A, laminates clamped between two pairs of loading rails are tested. When loaded in tension the rails introduce shear forces in the specimen. In Procedure B, laminates clamped on opposite edges with a tensile or compressive load applied to a third pair of rails in the center are tested.

1.2 Application of this test method is limited to continuous-fiber or discontinuous-fiber-reinforced polymer matrix composites in the following material forms:

1.2.1 Laminates composed only of unidirectional fibrous laminae, with the fiber direction oriented either parallel or perpendicular to the fixture rails.

1.2.2 Laminates composed only of woven fabric filamentary laminae with the warp direction oriented either parallel or perpendicular to the fixture rails.

1.2.3 Laminates of balanced and symmetric construction, with the 0° direction oriented either parallel or perpendicular to the fixture rails.

1.2.4 Short-fiber-reinforced composites with a majority of the fibers being randomly distributed.

NOTE 1—Additional test methods for determining in-plane shear properties of polymer matrix composites may be found in Test Methods [D 5379/D 5379M](#) and [D 5448/D 5448M](#), and Practice [D 3518/D 3518M](#).

1.3 *This standard does not purport to address all of the safety concerns, if any, associated with its use. It is the responsibility of the user of this standard to establish appropriate safety and health practices and determine the applicability of regulatory limitations prior to use.*

1.4 The values stated in either SI units or inch-pound units are to be regarded separately as standard. Within the text the inch-pounds units are shown in brackets. The values stated in each system are not exact equivalents; therefore, each system

must be used independently of the other. Combining values from the two systems may result in nonconformance with the standard.

2. Referenced Documents

2.1 *ASTM Standards:*²

[D 792](#) Test Methods for Density and Specific Gravity (Relative Density) of Plastics by Displacement

[D 883](#) Terminology Relating to Plastics

[D 2584](#) Test Method for Ignition Loss of Cured Reinforced Resins

[D 2734](#) Test Methods for Void Content of Reinforced Plastics

[D 3171](#) Test Methods for Constituent Content of Composite Materials

[D 3518/D 3518M](#) Test Method for In-Plane Shear Response of Polymer Matrix Composite Materials by Tensile Test of a $\pm 45^\circ$ Laminate

[D 3878](#) Terminology for Composite Materials

[D 5229/D 5229M](#) Test Method for Moisture Absorption Properties and Equilibrium Conditioning of Polymer Matrix Composite Materials

[D 5379/D 5379M](#) Test Method for Shear Properties of Composite Materials by the V-Notched Beam Method

[D 5448/D 5448M](#) Test Method for Inplane Shear Properties of Hoop Wound Polymer Matrix Composite Cylinders

[E 4](#) Practices for Force Verification of Testing Machines

[E 6](#) Terminology Relating to Methods of Mechanical Testing

[E 111](#) Test Method for Young's Modulus, Tangent Modulus, and Chord Modulus

[E 122](#) Practice for Calculating Sample Size to Estimate, With a Specified Tolerable Error, the Average for a Characteristic of a Lot or Process

[E 177](#) Practice for Use of the Terms Precision and Bias in ASTM Test Methods

[E 251](#) Test Methods for Performance Characteristics of

¹ This test method is under the jurisdiction of ASTM Committee D30 on Composite Materials and is the direct responsibility of Subcommittee D30.04 on Lamina and Laminate Test Methods.

Current edition approved May 1, 2007. Published June 2007. Originally approved in 1983. Last previous edition approved in 2001 as D 4255/D 4255M – 01.

² For referenced ASTM standards, visit the ASTM website, www.astm.org, or contact ASTM Customer Service at service@astm.org. For *Annual Book of ASTM Standards* volume information, refer to the standard's Document Summary page on the ASTM website.

Metallic Bonded Resistance Strain Gages

- E 456** Terminology Relating to Quality and Statistics
- E 1237** Guide for Installing Bonded Resistance Strain Gages
- E 1309** Guide for Identification of Fiber-Reinforced Polymer-Matrix Composite Materials in Databases
- E 1434** Guide for Recording Mechanical Test Data of Fiber-Reinforced Composite Materials in Databases
- E 1471** Guide for Identification of Fibers, Fillers, and Core Materials in Computerized Material Property Databases

2.2 *ASTM Adjunct:*

Adjunct No. **ADJD4255**, Rail Shear Fixtures Machining Drawings³

3. Terminology

3.1 Terminology **D 3878** defines terms relating to high-modulus fibers and their composites. Terminology **D 883** defines terms relating to plastics. Terminology **E 6** defines terms relating to mechanical testing. Terminology **E 456** and Practice **E 177** define terms relating to statistics. In the event of a conflict between terms, Terminology **D 3878** shall have precedence over the other terminology standards.

NOTE 2—If the term represents a physical quantity, its analytical dimensions are stated immediately following the term (or letter symbol) in fundamental dimension form, using the following ASTM standard symbology for fundamental dimensions, shown within square brackets: [M] for mass, [L] for length, [T] for time, [θ] for thermodynamic temperature, and [nd] for nondimensional quantities. Use of these symbols is restricted to analytical dimensions when used with square brackets, as the symbols may have other definitions when used without the brackets.

3.2 *Definitions of Terms Specific to This Standard:*

3.2.1 *in-plane shear, n*—shear associated with shear forces applied to the edges of the laminate so that the resulting shear deformations occur in the plane of the laminate rather than through the thickness.

3.2.2 *offset shear stress* [M/(LT²)], *n*—the shear stress associated with an offset of the shear chord modulus of elasticity line along the strain axis (see 12.4).

3.2.3 *shear strength* [M/(LT²)], *n*—the shear stress carried by a material at failure under a pure shear condition.

3.2.4 *transition region, n*—a strain region of a stress-strain or strain-strain curve over which a significant change in the slope of the curve occurs within a small strain range.

3.2.4.1 *Discussion*—Many filamentary composite materials exhibit a nonlinear response during loading, such as seen in plots of either longitudinal stress versus longitudinal strain or transverse strain versus longitudinal strain. In certain cases, the nonlinear response may be conveniently approximated by a bilinear fit. There are several physical reasons for the existence of a transition region. Common examples include matrix cracking under tensile loading and ply delamination.

3.2.5 *traveler, n*—a small piece of the same material as, and processed similarly to, the test specimen, used for example to measure moisture content as a result of conditioning. This is also sometimes termed as a reference sample.

³ A copy of the detailed drawing for the construction of the fixtures shown in Figs. 1 and 2 is available at a nominal cost from ASTM Headquarters. Request Adjunct No. **ADJD4255**.

3.3 *Symbols:*

- A* = cross-sectional area of test specimen
- B_y* = percent bending of specimen
- CV* = coefficient of variation statistic of a sample population for a given property, %
- F₁₂^o* = offset shear stress, the value of the shear stress at the intersection of the stress-strain plot with a line passing through the offset strain value at zero stress and with a slope equal to the shear chord modulus of elasticity
- F^u* = ultimate shear stress
- G* = shear modulus of elasticity
- h* = specimen thickness
- l* = specimen length, the dimension parallel to the rails in the gage section
- n* = number of specimens
- P_i* = load carried by test specimen at *i*th data point
- P^{max}* = load carried by a test specimen that is the lesser of (1) the maximum load before failure, (2) the load at 5 % shear strain, or (3) the load at the bending limit (see 11.8.1)
- s_{n-1}* = sample standard deviation
- x_i* = measured or derived property for an individual specimen from the sample population
- $\bar{\chi}$ = sample mean (average)
- γ = shear strain
- ϵ = indicated normal strain from strain transducer
- $\mu\epsilon = 10^{-6}$ m/m (10⁻⁶ in./in.)
- τ_i = shear stress at *i*th data point

4. Summary of Test Method

4.1 *Procedure A: Two-Rail Shear Test*—A flat panel with holes along opposing edges is clamped, usually by through bolts, between two pairs of parallel steel loading rails, see Figs. 1 and 2. When loaded in tension, this fixture introduces shear forces in the specimen that produce failures across the panel. This test method is typical but not the only configuration usable. The two-rail shear fixtures can also be compression loaded. The load may be applied to failure.

4.1.1 If load-strain data are required, the specimen may be instrumented with strain gages. Two three-element strain gage rosettes are installed at corresponding locations on both faces of the specimen.

4.2 *Procedure B: Three-Rail Shear Test*—A flat panel, clamped securely between pairs of rails on opposite edges and in its center, is loaded by supporting the side rails while loading the center rails. See Figs. 3-5. A load on the center rail of either tension or compression produces a shear load in each section of the specimen. The load may be applied to failure.

4.2.1 The test fixture consists of three pairs of parallel rails usually bolted to the test specimen by through bolts. The two outside pairs of rails are attached to a base plate which rests on the test machine. A third pair (middle rails) is guided through a slot in the top of the base fixture. The unit is normally loaded in compression. It is also permissible to load the middle rails in tension, but this requires attaching the base fixture to the test machine.

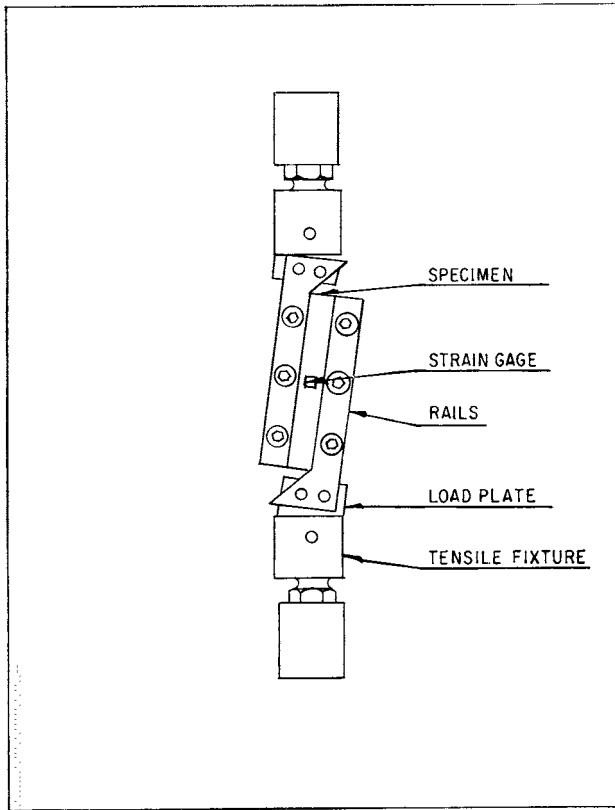

FIG. 1 Procedure A Assembly Rail Shear Apparatus

4.2.2 If load-strain data are required, the specimen may be instrumented with strain gages. Three-element strain gage rosettes are to be installed at corresponding locations on opposite faces of the specimen.

4.3 Detailed fixture drawings are available as ASTM Adjunct No. ADJD4255.

5. Significance and Use

5.1 These shear tests are designed to produce in-plane shear property data for material specifications, research and development, and design. Factors that influence the shear response and should therefore be reported include: material, methods of material preparation and lay-up, specimen stacking sequence, specimen preparation, specimen conditioning, environment of testing, specimen alignment and gripping, speed of testing, time at temperature, void content, and fiber volume reinforcement content. Properties that may be measured by this test method include:

5.1.1 In-plane shear stress versus shear strain response,

5.1.2 In-plane shear chord modulus of elasticity,

5.1.3 Offset shear stress, and

5.1.4 Maximum in-plane shear stress. In cases in which the strain at failure is greater than 5 %, the shear stress corresponding to 5 % shear strain should be reported.

6. Interferences

6.1 There are no standard test methods capable of producing a perfectly pure and uniform shear stress condition to failure for every material, although some test methods can come

acceptably close for a specific material for a given engineering purpose. The off-axis load of the two-rail method introduces a comparatively small tensile load in the panel.

6.2 *Material and Specimen Preparation*—Poor material fabrication practices, lack of control of fiber alignment, and damage induced by improper specimen machining are known causes of high material data scatter in composites.

6.3 *Determination of Failure*—Rail shear specimens, especially thin ones, can buckle during load application. Buckling can be detected by measuring surface strains on opposite faces of the specimens with three-element strain gage rosettes. Data measured with the specimen in a buckled state are not representative of the material shear properties. Modulus data must be checked to confirm that buckling has not occurred in the modulus measurement range. Strength measurements must be checked to confirm that shear strength has not been influenced by specimen buckling. Failure by buckling should not be interpreted as indicating the maximum shear strength.

6.3.1 Ply delamination is another possible failure mode for laminates containing a large number of 45° plies. This failure reflects instability of 45° plies loaded in compression as contrasted to the overall buckling failure previously described. Differences in strain gage readings will not be noticeable, but the failure can be identified by delaminated plies in contrast to fiber breakage.⁴

6.4 *Gripping*—Failure through bolt holes indicates inadequate gripping. Alternate gripping methods are discussed in 7.2.3.

6.5 *End Effects*—This test method assumes a state of pure shear throughout the length of the specimen gage section. However, the gage section ends have zero shear stress because no traction and no constraints are applied there. A stress transition region exists between the ends and interior portions of the gage section. The length of this transition region determines the error induced in the material shear data.

7. Apparatus

7.1 *Micrometers*—The micrometer(s) shall use a suitable size diameter ball interface on irregular surfaces such as the bag-side of a laminate and a flat anvil interface on machined edges or very-smooth tooled surfaces. The accuracy of the instruments shall be suitable for reading to within 1 % of the sample length and thickness. For typical specimen geometries, an instrument with an accuracy of $\pm 2.5 \mu\text{m}$ [$\pm 0.0001 \text{ in.}$] is desirable for thickness measurement, while an instrument with an accuracy of $\pm 25 \mu\text{m}$ [$\pm 0.001 \text{ in.}$] is desirable for length measurement.

7.2 Rail Shear Fixtures

7.2.1 *Two-Rail Shear*—A two-rail shear fixture is shown in Figs. 1 and 2. Detailed fixture drawings are available as ASTM Adjunct No. ADJD4255. The test fixture consists of two pairs of rails which can clamp the test specimen with through bolts. The rails are then attached to the test machine through pins, a load plate that also aligns the rails with each other, and a clevis

⁴ A. K. Hussain and D. F. Adams, "The Wyoming-Modified Two-Rail Shear Test Fixture for Composite Materials," *Journal of Composites Technology and Research*, Vol 21, No. 4, October 1999, pp. 215-223.

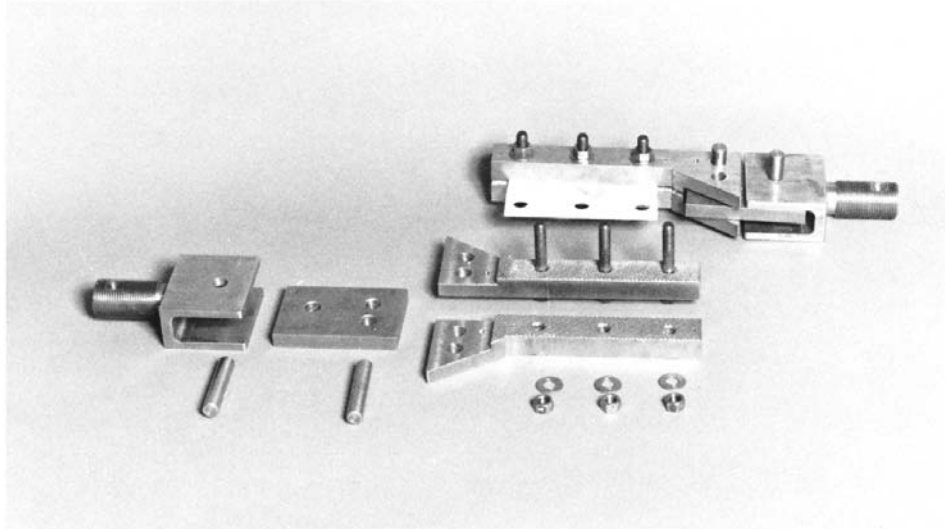

FIG. 2 Procedure A Partially Assembled Typical Test Fixture

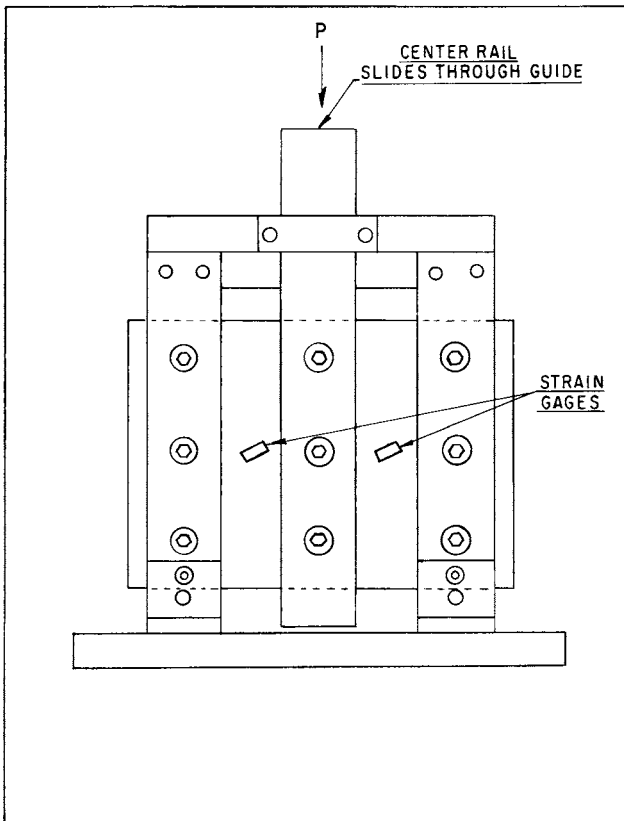

FIG. 3 Procedure B Assembly Rail Shear Fixture

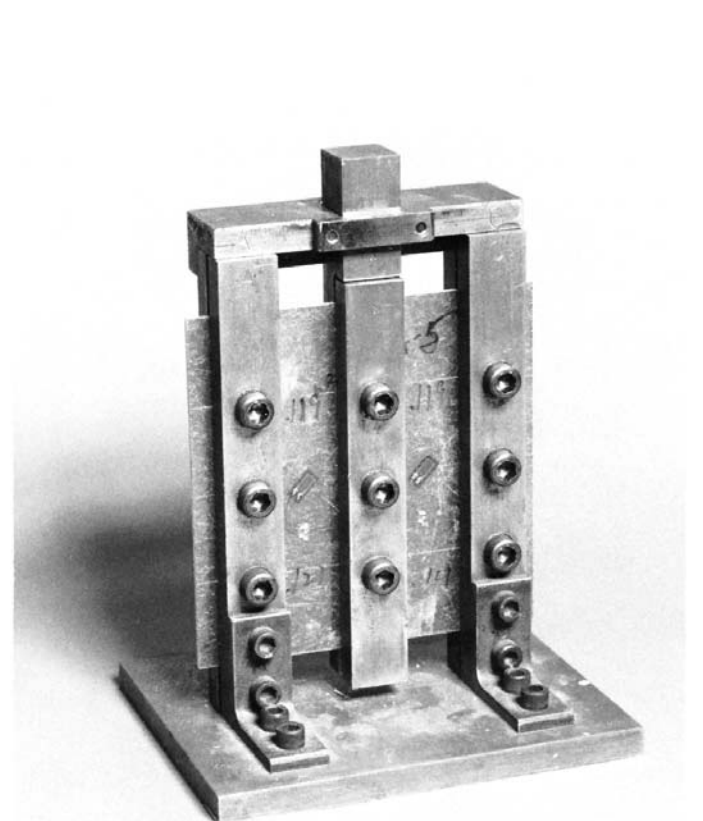

FIG. 4 Procedure B Assembled Typical Test Fixture

that connects directly to the test machine. This equipment is typical but not the only configuration usable. The two-rail shear fixture can be compression loaded. Also see 7.2.3 for rail modifications.

7.2.2 *Three-Rail Shear*—A three-rail shear fixture is shown in Figs. 3-5. Detailed fixture drawings are available as ASTM Adjunct ADJD4255. The test fixture consists of three pairs of rails that clamp the test specimen with through bolts. The two

outside pairs of rails are attached to a base plate that rests on the test machine. The third (middle) pair of rails are guided through a slot in the top of the base fixture. The unit shown is loaded in compression. The middle rails can be tensile loaded,

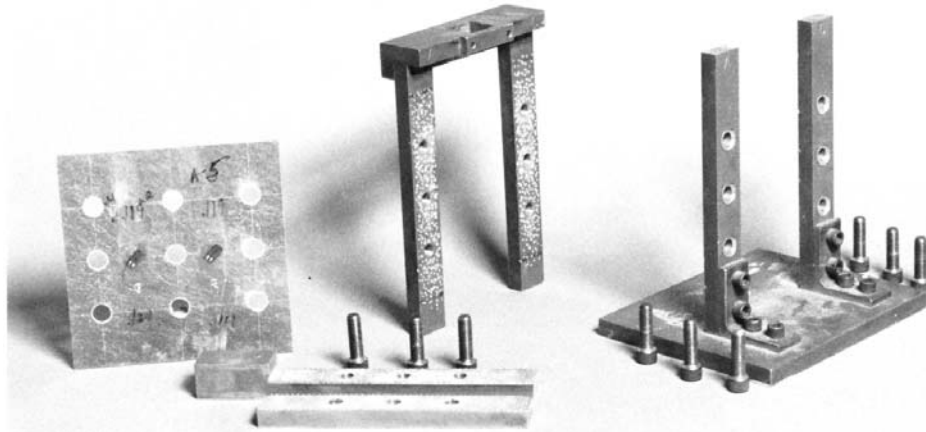

FIG. 5 Procedure B Disassembled Typical Test Fixture

which requires fastening the base fixture to the test machine. This equipment is typical but not the only configuration that is usable. Also see 7.2.3 for rail modifications.

7.2.3 *Rail Modifications*—The following list is not inclusive but is typical of methods used by various laboratories to meet the requirements of specific materials. Techniques that work for one material may be unacceptable for another. If these modifications are to be used as part of a specification, the rail grip system shall be completely specified and these modifications noted in the test report. These modifications have been used to grip the following specimens:

- 7.2.3.1 Abrasive paper or cloth bonded to the rails,
- 7.2.3.2 Machining V grooves in the rails,
- 7.2.3.3 Center punching rails in a random pattern,
- 7.2.3.4 Changing the number of bolt holes from three up to eight per rail and using smaller holes,
- 7.2.3.5 Soft metal shims,
- 7.2.3.6 Tabbing specimens in rail areas, and
- 7.2.3.7 Thermal spray surfaces.

7.3 *Testing Machine*—The testing machine shall conform with Practices E 4 and shall satisfy these requirements:

7.3.1 *Testing Machine Heads*—The testing machine shall have two loading heads with at least one movable head along the testing axis.

7.3.2 *Platens/Adapter*—One of the testing machine heads shall be capable of being attached to the lower half of the two-rail shear test fixture (described in 7.2.1) or of supporting the base of the three-rail fixture (described in 7.2.2) using an adapter or platen interface as required. The other head shall be capable of being attached to the upper half of the fixture or of loading the center rail of the fixture. If required, one of the

interfaces may be capable of relieving minor misalignments between heads, such as with a universal or a hemispherical ball joint.

7.3.3 *Drive Mechanism*—The testing machine drive mechanism shall be capable of imparting to the movable head a controlled displacement rate with respect to the stationary head. The displacement of the movable head shall be capable of regulation as specified in 11.3.

7.3.4 *Load Indicator*—The testing machine load-sensing device shall be capable of indicating the total load applied to the test specimen. This device shall be essentially free from response lag at the specified testing rate and shall indicate the load with an accuracy over the load range(s) of interest of within $\pm 1\%$ of the indicated value, as specified by Practices E 4. The load range(s) of interest may be fairly low for modulus evaluation or much higher for strength evaluation, or both, as required.

NOTE 3—Obtaining precision load data over a large range of interest in the same test, such as when both elastic modulus and maximum load are being determined, places extreme requirements on the load cell and its calibration. For some equipment a special calibration may be required. For some combinations of material and load cell, simultaneous precision measurement of both elastic modulus and maximum strength may not be possible, and measurement of modulus and strength may have to be performed in separate tests using a different load cell range for each test.

7.4 *Strain-Indicating Device*—Bonded resistance strain gages shall be used to measure strain. A minimum of two three-element strain gage rosettes are required, at corresponding locations on opposite faces of the specimen at the center of the gage section, as illustrated in Fig. 1, Fig. 3, and Figs. 6-9.

7.4.1 *Bonded Resistance Strain Gages*—Strain gage selection is a compromise based on the type of material. An active

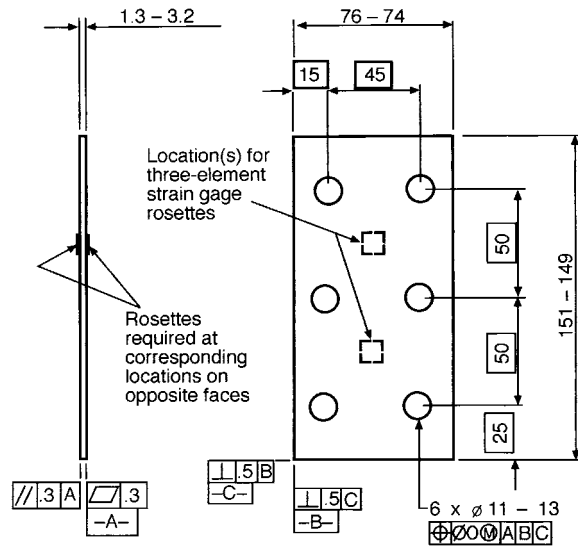

FIG. 6 Procedure A, Two-Rail Shear Specimen, SI Units

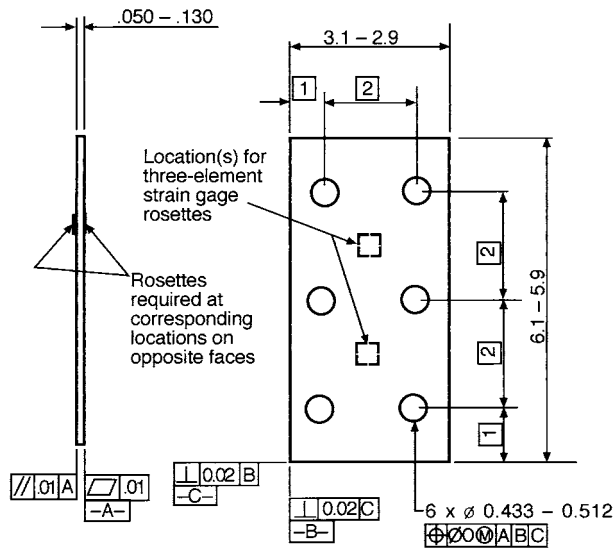

FIG. 7 Procedure A, Two-Rail Shear Specimen, Inch-Pound Units

gage length of 3 mm [0.125 in.] is recommended for most materials, although larger gages may be more suitable for some woven fabrics. The gage should not be so large that it lies within four specimen thicknesses of a rail. Gage calibration certification shall comply with Test Methods E 251. Strain gage rosettes with a minimum normal strain range of approximately 3 % (measuring 6 % shear strain) are recommended. When testing woven fabric laminates, gage selection should consider the use of an active gage length that is at least as large as the characteristic repeating unit of the weave. Some guidelines on strain gage use on composites follow. Additional general information can be found in the literature.^{5,6}

⁵ M. E. Tuttle and H. F. Brinson, "Resistance-Foil Strain Gage Technology as Applied to Composite Materials," *Experimental Mechanics*, 1984, Vol 24, No. 1, pp. 54-65, Errata noted in Vol. 26, No. 2, June 1986, pp. 153-154.

⁶ *Manual on Experimental Methods of Mechanical Testing of Composites*, C. H. Jenkins, Ed., second edition, Society for Experimental Mechanics, Section II, Strain Measurement, 1998, pp. 25-84.

7.4.1.1 Surface preparation of fiber-reinforced composites in accordance with Guide E 1237 can penetrate the matrix material and cause damage to the reinforcing fibers, resulting in improper specimen failures. Reinforcing fibers should not be exposed or damaged during the surface preparation process. Consult the strain gage manufacturer regarding surface preparation guidelines and recommended bonding agents for composites, pending the development of a set of standard practices for strain gage installation surface preparation of fiber-reinforced composite materials.

7.4.1.2 Select gages having higher resistances to reduce heating effects on low-conductivity materials.⁷ Resistances of 350 Ω or higher are preferred. Use the minimum possible gage excitation voltage consistent with the desired accuracy (1 to 2

⁷ D. F. Adams and E. Q. Lewis, "Influence of Specimen Gage Length and Loading Method on the Axial Compression Strength of a Unidirectional Composite Material," *Experimental Mechanics*, Vol 31, No. 1, 1991, pp. 14-20.

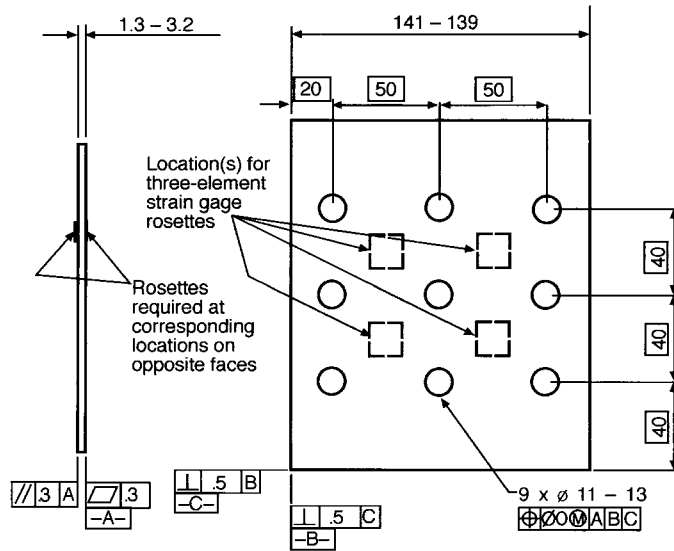

FIG. 8 Procedure B, Three-Rail Shear Specimen, SI Units

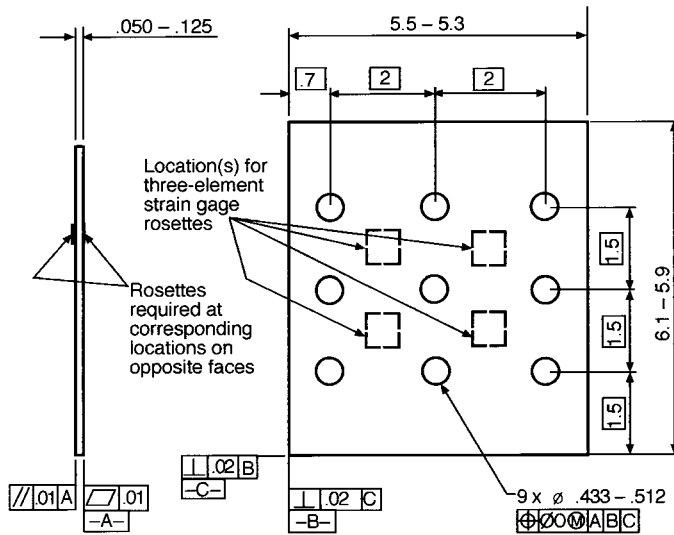

FIG. 9 Procedure B, Three-Rail Shear Specimen, Inch-Pound Units

V is recommended) to reduce the power consumed by the gage further. Heating of the specimen by the gage may affect the performance of the material directly, or it may affect the indicated strain as a result of a difference between the gage temperature compensation factor and the coefficient of thermal expansion of the specimen material.

7.4.1.3 Temperature compensation is recommended when testing at Standard Laboratory Atmosphere. Temperature compensation is required when testing in nonambient temperature environments. When appropriate, use a traveler with identical lay-up and strain gage orientations for thermal strain compensation.

7.4.1.4 Correct for strain gage transverse sensitivity when the error caused by strain gage transverse sensitivity is greater than 1 %. Strain measurements using strain gages mounted to composite materials are susceptible to transverse sensitivity errors because of the highly orthotropic behavior of composite materials. Unidirectional composites are especially susceptible to strain gage transverse sensitivity errors.

7.4.1.5 Strain gage rosettes are required on opposite faces of the test specimen to detect buckling deformation. When the specimen bends as a result of buckling, strains on one face of the specimen exceed strains on the opposite face.

7.5 *Conditioning Chamber*—When conditioning materials in other than ambient laboratory environments, a temperature/vapor-level-controlled environmental conditioning chamber is required that shall be capable of maintaining the required relative temperature to within $\pm 3^{\circ}\text{C}$ [$\pm 5^{\circ}\text{F}$] and the required relative vapor level to within $\pm 3\%$. Chamber conditions shall be monitored either on an automated continuous basis or on a manual basis at regular intervals.

7.6 *Environmental Test Chamber*—An environmental test chamber is required for test environments other than ambient testing laboratory conditions. This chamber shall be capable of maintaining the gage section of the test specimen within $\pm 3^{\circ}\text{C}$ [$\pm 5^{\circ}\text{F}$] of the required test temperature during the mechanical test. In addition, the chamber may have to be capable of

maintaining environmental conditions such as fluid exposure or relative humidity during the test (see 11.4).

NOTE 4—If specimens are to undergo environmental conditioning to equilibrium, and are of such type or geometry that the weight change of the material cannot be properly measured by weighing the specimen itself (such as a tabbed mechanical specimen), then another traveler specimen (reference sample) of the same nominal thickness and appropriate size (but without tabs) shall be used to determine when equilibrium has been reached for the specimens being conditioned.

8. Sampling and Test Specimens

8.1 *Sampling*—Test at least five specimens per test condition unless valid results can be gained through the use of fewer specimens, such as in the case of a designed experiment. Consult Practice E 122 to determine statistically appropriate sample sizes. The method of sampling shall be reported.

8.2 *Geometry*—The specimens are rectangular panels with rows of holes for rail clamping bolts to pass through. It is recommended that laminates be 1.3 to 3.2 mm [0.050 to 0.13 in.] thick. Thin laminates buckle at low loads while thicker laminates can have shear strengths exceeding the rail-clamping capacity. Thicker specimens are preferred for strength measurements because of their higher buckling stability. However, thicker specimens may not permit spacing of strain gage rosettes four specimen thicknesses from the rail edges, as specified in 7.4.1. The mandatory specimen requirements are described in 8.2.1 and 8.2.2.

8.2.1 *Two-Rail Shear Procedure*—The recommended test specimen shall conform to the dimensions shown in Fig. 6 (SI units) or Fig. 7 (inch-pound units) and ASTM Adjunct ADJD4255. Specimen flatness is essential to minimize the likelihood of buckling. Note that while the sample outer dimensions are uniform, many variations of hole patterns and tabbed edges have been used. See 8.3 and 8.4.

8.2.2 *Three-Rail Shear Procedure*—The test specimen shall conform to the dimensions shown in Fig. 8 (SI units) or Fig. 9 (inch-pound units) and ASTM Adjunct ADJD4255. Specimen flatness is essential to minimize the likelihood of buckling.

8.3 *Use of Tabs*—Tabs are not required. The key factor in the selection of specimen tolerances and gripping methods is the successful introduction of load in the specimen and the prevention of premature failure as a result of slipping. Therefore, the need to use tabs and specification of tab design parameters shall be determined by the end result: acceptable failure mode and location. If acceptable failure modes occur with reasonable frequency, then there is no reason to change a given gripping method.

8.3.1 *Tab Geometry*—Tab thickness may vary, but is commonly 1.5 mm [0.06 in.]. The selection of a tab configuration that can successfully produce a gage section failure without slipping is dependent upon the specimen material, specimen ply orientation, and the type of grips being used. For alignment purposes it is essential that the tabs be of matched thicknesses and the tab surfaces be parallel.

8.3.2 *Friction Tabs*—Tabs need not always be bonded to the material under test to be effective in introducing the load into the specimen. Friction tabs, essentially nonbonded tabs held in place by the pressure of the grip, and often used with emery cloth or some other light abrasive between the tab and the

specimen, have been successfully used in some applications. In specific cases, lightly serrated wedge grips have been successfully used with only emery cloth as the interface between the grip and the specimen. However, the abrasive used must be able to withstand significant compressive loads. Some types of emery cloth have been found ineffective in this application as a result of disintegration of the abrasive.

8.3.3 *Tab Material*—When tabs are used, the most commonly used materials are steel and continuous E-glass fiber-reinforced polymer matrix materials (woven or unwoven), in a [0/90]_{ns} laminate configuration.

8.3.4 *Adhesive Material*—Any high-elongation (tough) adhesive system that meets the environmental requirements may be used when bonding tabs to the material under test. A uniform bondline of minimum thickness is desirable to reduce undesirable stresses in the assembly.

8.4 *Bolt Holes*—A larger number of smaller holes may be used in each rail pair to improve specimen clamping. Up to eight holes have been used successfully. The holes as shown are oversize to the bolts, although press-fit bolts have been used with success, particularly with tabbed specimens.

8.5 Specimen Preparation:

8.5.1 *Panel Fabrication*—Control of fiber alignment is important. Improper fiber alignment will reduce the measured properties. Improper fiber alignment will also increase the coefficient of variation. Suggested methods of maintaining fiber alignment have been discussed.⁷ The panel preparation method used shall be reported.

8.5.2 *Machining*—The straight edges of the specimen may have coarse tool marks from the machining operation. However, the holes should be drilled and reamed if minor delamination occurs.

8.5.3 *Labeling*—Label the specimens so that they will be distinct from each other and traceable back to the raw material and in a manner that will both be unaffected by the test and not influence the test.

9. Calibration

9.1 The accuracy of all measuring equipment shall have certified calibrations that are current at the time of use of the equipment.

10. Conditioning

10.1 *Standard Conditioning Procedure*—Unless a different environment is specified as part of the experiment, condition the test specimens in accordance with Procedure C of Test Method D 5229/D 5229M and store and test at standard laboratory atmosphere ($23 \pm 3^\circ\text{C}$ [$73.4 \pm 5.4^\circ\text{F}$] and $50 \pm 10\%$ relative humidity).

11. Procedure

11.1 Parameters to Be Specified Before Test:

11.1.1 The shear specimen sampling method, specimen type and geometry, and conditioning travelers (if required).

11.1.2 The shear properties and data reporting format desired.

NOTE 5—Determine specific material property, accuracy, and data reporting requirements before test for proper selection of instrumentation

and data recording equipment. Estimate operating stress and strain levels to aid in transducer selection, calibration of equipment, and determination of equipment settings.

11.1.3 The environmental conditioning test parameters.

11.1.4 If performed, the sampling method, specimen geometry, and test parameters used to determine density and reinforcement volume.

11.2 *General Instructions:*

11.2.1 Report any deviations from this test method, whether intentional or inadvertent.

11.2.2 If specific gravity, density, reinforcement volume, or void volume are to be reported, then obtain these samples from the same panels as the test samples. Specific gravity and density may be evaluated by means of Test Methods **D 792**. Volume percent of the constituents may be evaluated by one of the matrix digestion procedures of Test Method **D 3171**, or, for certain reinforcement materials such as glass and ceramics, by the matrix burn-off technique of Test Method **D 2584**. Void content may be evaluated from the equations of Test Method **D 2734** and are applicable to both Test Methods **D 2584** and **D 3171**.

11.2.3 Condition the specimens, either before or after strain gaging, as required.

NOTE 6—Gaging before conditioning may impede moisture absorption locally underneath the strain gage, or the conditioning environment may degrade the strain gage adhesive, or both. On the other hand, gaging after conditioning may not be possible for other reasons, or the gaging activity itself may cause loss of conditioning equilibrium. The timing on when to gage specimens is left to the individual application and shall be reported.

11.2.4 Following final specimen machining and any conditioning, but before the shear testing, measure specimen length, l , the specimen dimension parallel to the rails; and thickness, h , to the accuracy in **7.1**, at three locations in the gage section. Record the average values of the length and thickness measurements in units of millimetres [inches]. Verify that the hole positions and sizes satisfy the specified tolerances.

11.2.5 Apply strain gages to the specimen (see **7.4**) as shown in **Figs. 6-9**.

11.3 *Rate of Testing*—Set the rate of testing to effect a nearly constant strain rate in the gage section. If strain control is not available on the testing machine, this may be approximated by repeated monitoring and adjusting the displacement rate to maintain a nearly constant strain rate, as measured by the strain transducer. Select a strain rate to produce failure within 1 to 10 min from the beginning of load application. If the maximum strain of the material cannot be reasonably estimated, conduct initial trials using standard rates until the maximum strain of the material and the compliance of the system are known, and the strain rate can be adjusted. The suggested standard rates are as follows:

11.3.1 *Strain-Controlled Tests*—A standard strain rate of 0.01 min^{-1} .

11.3.2 *Constant Head-Speed Tests*—A standard crosshead displacement of 1.5 mm/min [0.05 in./min].

NOTE 7—Compliant tab materials can result in specimen strain rates substantially lower than apparent from crosshead speed. In some cases, actual strain rates 10 to 50 times lower than estimated by crosshead speeds have been observed.

11.4 *Test Environment*—Condition the specimen to the desired moisture profile and, if possible, test under the same conditioning fluid exposure level. However, cases such as elevated temperature testing of a moist specimen place unrealistic requirements on the capabilities of common testing machine environmental chambers. In such cases, the mechanical test environment may need to be modified, for example, by testing at elevated temperature with no fluid exposure control, but with a specified limit on time to failure from withdrawal from the conditioning chamber. Record modifications to the test environment.

11.4.1 Store the specimen in the conditioned environment until test time, if the testing area environment is different than the conditioning environment.

11.4.2 Moisture loss during mechanical testing may occur if the test environment is different from the conditioning environment. This loss can be minimized by reducing exposure time in the test chamber although care should be taken to ensure that the specimen temperature is at equilibrium. Fixtures may be preheated, the temperature may be ramped up quickly, and the hold time at temperature may be minimized prior to testing. Environmentally conditioned travelers may be used to measure moisture loss during exposure to the test environment. Weigh a traveler before testing and place it in the test chamber at the same time as the specimen. Remove the traveler immediately after fracture and reweigh it to determine moisture loss.

11.4.3 Monitor the test temperature by placing an appropriate thermocouple within 25 mm [1.0 in.] of the specimen gage section. Maintain the temperature of the specimen, and the traveler, if one is being used, for thermal strain compensation or moisture loss evaluation, within $\pm 3^\circ\text{C}$ [$\pm 5^\circ\text{F}$] of the required condition. Taping thermocouple(s) to the test specimen (and the traveler) is an effective measurement method.

11.5 *Fixture Installation:*

NOTE 8—The following procedure is intended for vertical testing machines.

11.5.1 *Two-Rail Test Procedure:*

11.5.1.1 Inspect the fixture. Examine the fixture for signs of wear on the rails, bolt holes, load plate, tensile head, and connecting pins.

11.5.1.2 Attach the tensile heads to the upper and lower test machine heads.

11.5.2 *Three-Rail Test Procedure:*

11.5.2.1 Inspect the fixture. Examine the fixture for signs of wear on the rails, bolt holes, and center rail guide hole.

11.5.2.2 Mount the base on the lower test frame head. Mount hardware required for pressing on the center rail with the upper test machine head.

11.6 *Specimen Insertion:*

11.6.1 *Two-Rail Test Procedure:*

11.6.1.1 Place the specimen between the pairs of rails. Align pairs of rails with each other by inserting the connecting pins. Insert 10-mm [$\frac{3}{8}$ -in.] socket head cap screws through the rails and specimen holes and put on high-strength nuts loosely. Place a 12.7-mm [$\frac{1}{2}$ -in.] spacer between opposite pairs of rails. Align the rails with the specimen. Ensure that there is no bearing contact in the direction of loading between the screws

and the specimen holes. Tighten the nuts fingertight. Torque the bolts to 7 to 70 N-m [5 to 50 lbf-ft] (Note 9). Then torque each bolt to 100 N-m [70 lbf-ft]. Use of a fixture to position the rails and sample is helpful.

NOTE 9—Tightening the bolts or screws is very important; actual torque values may vary with materials or rail guides, or both. The most important factor is to tighten the rails uniformly. Overtightening must also be prevented. It is recommended that a fixed pattern of tightening be established and that the bolts be torqued in three stages: fingertight, then one quarter the final torque, then tighten to the final torque. An additional check of each bolt is advisable to see that all the bolts are at the established torque.

11.6.1.2 Mount the clamped specimen and rails between the loading heads and check for alignment of the test fixture in a vertical plane through the axis of load application.

11.6.1.3 Attach the strain recording instrumentation to the strain gages on the specimen.

11.6.2 Three-Rail Test Procedure:

11.6.2.1 Place the specimen between the pairs of rails on the base. Insert 10-mm [³/₈-in.] socket head cap screws through the front rails, specimen, and into the rear rails. Ensure that there is no bearing contact in the direction of loading between the screws and the specimen holes. Torque each screw to 7 to 70 N-m [5 to 50 lbf-ft] (Note 9). Torque each screw to 100 N-m [70 lbf-ft]. Insert the rear center rail through the guide hole. Place the front center rail on the other side of the specimen and fasten them together with socket head cap screws as for the side rails previously stated.

11.6.2.2 Place the test fixture with specimen in the testing machine taking care to align the center rail with the movable member of the machine. Alignment can be improved by using a spherical seat between the load head and center rail if compression loading is used.

11.6.3 Attach the strain recording instrumentation to the strain gages on the specimen.

11.7 Loading:

11.7.1 Preload—Preload the specimen and fixture (less than 5 % of failure load) and release to align the heads and rails and zero the strain gages.

11.7.2 Load the specimen at the specified rate until failure, while recording data.

11.8 Data Recording—Record load versus strain continuously or at frequent regular intervals. If a transition region or initial ply failures are noted, record the load, strain, and mode of damage at such points. If the specimen is to be failed, record the maximum load, the failure load, and the strain (or transducer displacement) at, or as near as possible to, the moment of failure. Terminate the test at 5 % shear strain.

NOTE 10—Other valuable data that can be useful in understanding testing anomalies and gripping or specimen slipping problems includes load versus head displacement data and load versus time data.

11.8.1 A difference in the stress-strain or load-strain slope from opposite faces of the specimen indicates bending in the specimen. For the elastic property test results to be considered valid, percent bending shall be less than 10 % as determined by Eq 1. Determine percent bending at the midpoint of the strain range used for chord modulus calculations (see 12.4.1). The same requirement shall be met at failure strain for the strength

and strain-to-failure data to be considered valid. This requirement shall be met for all specimens requiring back-to-back strain measurement. If possible, a plot of percent bending versus average strain should be recorded to aid in the determination of failure mode.

$$B_y = \frac{|\epsilon_1 - \epsilon_2|}{|\epsilon_1 + \epsilon_2|} \times 100 \leq 10 \% \quad (1)$$

where:

- B_y = percent bending in specimen,
- ϵ_1 = indicated strain from Gage 1,
- ϵ_2 = indicated strain from Gage 2, and
- ϵ_{ave} = average strain $(\epsilon_1 + \epsilon_2)/2$ at the data point closest to the strain checkpoint for bending.

11.8.2 Rapid divergence of the strain readings on the opposite faces of the specimen or rapid increase in percent bending is indicative of the onset of instability. For shear property calculations discard all data for loads higher than the buckling load at or immediately prior to failure.

11.9 Record the mode of failure.

12. Calculation

12.1 Before calculating material properties, examine the strain data to confirm that an acceptable state of shear strain was induced in the specimen and to determine if buckling occurred. The strains in the zero-degree direction as shown in Figs. 6-9 should remain small compared to the magnitudes of the $\pm 45^\circ$ strains. If the zero degree strain magnitudes are greater than 10 % of the $\pm 45^\circ$ strain magnitudes material properties, calculations should be based on calculated values of maximum shear strains. Also report the values and directions of principal extensional strains. Strain transformation equations are available in many stress analysis textbooks, for example, Footnote 11.

12.2 Ultimate Shear Stress/Shear Stress:

12.2.1 Two-Rail Shear Procedure—Calculate the ultimate in-plane shear stress as the lesser of the maximum shear stress before failure and the shear stress at 5 % shear strain. Use Eq 2 and report the results to three significant digits. If the shear modulus is to be calculated, determine the shear stress at each required data point using Eq 3.

$$F^u = P^{max}/A \quad (2)$$

$$\tau_i = P_i/A \quad (3)$$

where:

- F^u = ultimate shear stress, MPa [psi];
- P^{max} = load carried by a test specimen that is the lesser of (1) the maximum load before failure, (2) the load at 5 % shear strain, or (3) the load at the bending limit (see 11.8.1), N [lbf];
- τ_i = shear stress at the i th data point, MPa [psi];
- P_i = load at i th data point, N [lbf]; and
- A = cross-sectional area at test section calculated as the product of the average length, l , and average thickness, h , mm^2 [$in.^2$].

12.2.2 Three-Rail Shear Procedure—Calculate the ultimate in-plane shear stress as the lesser of the maximum shear stress before failure and the shear stress at 5 % shear strain. Use Eq 4 and report the results to three significant digits. If the shear

modulus is to be calculated, determine the shear stress at each required data point using Eq 5.

$$F^u = P^{max}/2A \tag{4}$$

$$\tau_i = P_i/2A \tag{5}$$

where:

- F^u = ultimate shear stress strength, MPa [psi];
- P^{max} = load carried by a test specimen that is the lesser of (1) the maximum load before failure, (2) the load at 5 % shear strain, or (3) the load at the bending limit (see 11.8.1), N [lbf];
- τ_i = shear stress at the i th data point, MPa [psi];
- P_i = load at i th data point, N [lbf]; and
- A = cross-sectional area at test section calculated as the product of the average length, l , and average thickness, h , mm² [in.²].

12.3 *Shear Strain/Ultimate Shear Strain*—If shear modulus or ultimate shear strain is to be calculated, determine the shear strain at each required data point from the indicated normal strains at +45° and -45° at each required data point using Eq 6. Report the results to three significant digits.

$$\gamma_i = |\epsilon_{+45}| + |\epsilon_{-45}| \tag{6}$$

where:

- γ_i = shear strain at i th data point, $\mu\epsilon$,
- ϵ_{+45} = normal strain in the +45° direction at i th data point, $\mu\epsilon$, and
- ϵ_{-45} = normal strain in the -45° direction at i th data point, $\mu\epsilon$.

12.4 *Shear Modulus of Elasticity:*

12.4.1 *Chord Shear Modulus of Elasticity*—Calculate the chord shear modulus of elasticity using Eq 8, applied over a $4000 \pm 200\text{-}\mu\epsilon$ shear strain range, starting with the lower strain point in the range from 1500 to 2500 $\mu\epsilon$, inclusive. Report the shear chord modulus of elasticity to three significant digits. Also report the strain range used in the calculation. A graphical example of chord shear modulus is shown in Fig. 10.

12.4.1.1 A different strain range must be used for materials that fail or exhibit a transition region (a significant change in the slope of the stress-strain curve) at strain less than 6000 $\mu\epsilon$. In such cases, the upper strain range value for the sample population shall be determined after testing; defined as 90 % of the average value of the upper limit of the essentially linear region, rounded downward to the nearest 500 $\mu\epsilon$. Any presence of a transition region shall be reported, along with the strain range used.

$$G^{chord} = \Delta\tau/\Delta\gamma \tag{7}$$

where:

- G^{chord} = chord modulus of elasticity, GPa [psi],
- $\Delta\tau$ = difference in applied shear stress between the two strain points, MPa [psi], and
- $\Delta\gamma$ = difference between the two shear strain points (nominally 0.004).

12.4.2 *Shear Modulus of Elasticity (Other Definitions)*—Other definitions of elastic modulus may be evaluated and reported at the user’s discretion. If such data are generated and reported, report also the definition used, the shear strain range used, and the results to three significant digits. Test Method E 111 provides additional guidance in the determination of modulus of elasticity.

NOTE 11—An example of another modulus definition is the secondary chord modulus of elasticity for materials that exhibit essentially bilinear stress-strain behavior. An example of secondary chord modulus is shown in Fig. 10.

12.5 *Offset Shear Strength*—If desired, an offset shear stress may be determined from the shear-stress versus shear-strain curve. Translate the shear chord modulus of elasticity line along the strain axis from the origin by a fixed strain value, and extend this line until it intersects the stress-strain curve. Determine the shear stress that corresponds to the intersection point and report this value, to three significant digits, as the offset shear strength, along with the value of the offset strain.

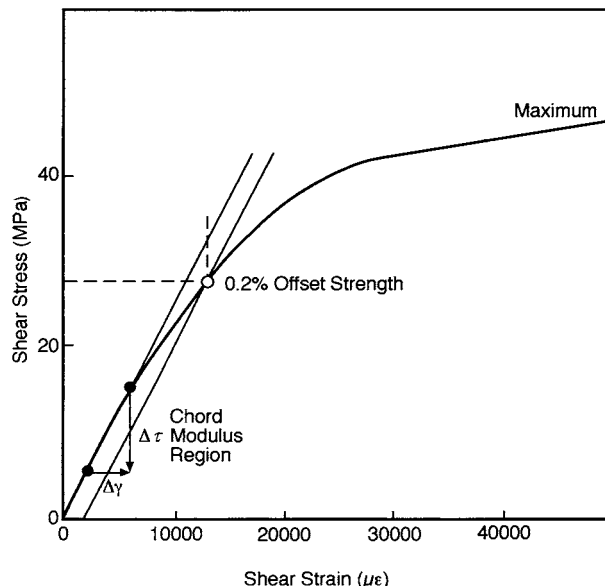

FIG. 10 Illustration of Modulus and Offset Strength Determination

Fig. 10 shows a graphical example of offset shear stress where $F_{12}^{\circ}(0.2\% \text{ offset}) = 28 \text{ MPa}$.

NOTE 12—In the absence of evidence suggesting the use of a more appropriate value, an offset strain value of 0.2 % is recommended.

12.6 *Statistics*—For each series of tests, calculate the average value, standard deviation, and coefficient of variation (in percent) for each property determined:

$$\bar{\chi} = (\sum_{i=1}^n x_i)/n \quad (8)$$

$$s_{n-1} = \sqrt{(\sum_{i=1}^n x_i^2 - n(\bar{\chi})^2)/(n-1)} \quad (9)$$

$$CV = 100 \times s_{n-1}/\bar{\chi} \quad (10)$$

where:

- $\bar{\chi}$ = sample mean (average);
- s_{n-1} = sample standard deviation;
- CV = sample coefficient of variation, %;
- n = number of specimens; and
- x_i = measured or derived property.

13. Report

13.1 All testing shall be reported in accordance with Guides **E 1434** and **E 1309**. The following information applies to the use of these guides for reporting data from Test Method D 4255/D 4255M. Report the following information, or references pointing to other documentation containing this information, to the maximum extent applicable. (Reporting of items beyond the control of a given testing laboratory, such as might occur with material details of panel fabrication parameters, shall be the responsibility of the requestor):

- 13.1.1 The revision level or date of issue of this test method.
- 13.1.2 The date(s) and location(s) of the test method.
- 13.1.3 The name(s) of the test operator(s).
- 13.1.4 Any variations to this test method, anomalies noticed during testing, or equipment problems occurring during testing.
- 13.1.5 Identification of the material tested including: material specification, material type, material designation, manufacturer, manufacturer's lot or batch number, source (if not from the manufacturer), date of certification, expiration of certification, filament diameter, tow or yarn filament count and twist, sizing, form or weave, fiber areal weight, matrix type, prepreg matrix content, and prepreg volatiles content.
- 13.1.6 Description of the fabrication steps used to prepare the laminate including: fabrication start date, fabrication end date, process specification, cure cycle, consolidation method, and a description of the equipment used.
- 13.1.7 Ply orientation stacking sequence of the laminate.
- 13.1.8 If requested, report density, reinforcement volume fraction, and void content test methods, specimen sampling method and geometries, test parameters, and test data.
- 13.1.9 Average ply thickness of the material.
- 13.1.10 Results of any nondestructive evaluation tests.
- 13.1.11 Method of preparing the test specimens, including specimen labeling scheme and method, specimen geometry, sampling method, specimen cutting method, identification of tab geometry, tab material, and tab adhesive used.

13.1.12 Calibration dates and methods for all measurement and test equipment.

13.1.13 Type of test machine, alignment data, and data acquisition sampling rate and equipment type.

13.1.14 Dimensions of each test specimen.

13.1.15 Conditioning parameters and results, use of travelers and traveler geometry, and the procedure used if other than that specified in this test method.

13.1.16 Relative humidity and temperature of the testing laboratory.

13.1.17 Environment of the test machine environmental chamber (if used) and soak time at environment.

13.1.18 Number of specimens tested.

13.1.19 Speed of testing.

13.1.20 Transducer placement on the specimen, transducer type, and calibration data for each transducer used.

13.1.21 The strain gage type, resistance, size, gage factor, temperature compensation method, transverse sensitivity, lead-wire resistance, and any correction factors employed.

13.1.22 Load-displacement and stress-strain curves for each specimen.

13.1.23 Tabulated data of stress versus strain for each specimen.

13.1.24 Individual strengths and average value, standard deviation, and coefficient of variation (in percent) for the population. Note if the failure load was less than the maximum load prior to failure.

13.1.25 Individual strains at failure and the average value, standard deviation, and coefficient of variation (in percent) for the population.

13.1.26 Strain range used for chord shear modulus determination.

13.1.27 If another definition of modulus of elasticity is used in addition to chord modulus, describe the method used, the resulting correlation coefficient (if applicable), and the strain range used for the evaluation.

13.1.28 Individual values of shear chord modulus of elasticity, and the average value, standard deviation, and coefficient of variation (in percent) for the population.

13.1.29 Individual values of offset shear strength with the value of the offset strain, along with the average, standard deviation, and coefficient of variation (in percent) values for the population.

13.1.30 Individual maximum shear stresses, and the average, standard deviation, and coefficient of variation (in percent) values for the population. Note any test in which the failure load was less than the maximum load before failure.

13.1.31 Individual maximum shear strains and the average, standard deviation, and coefficient of variation (in percent) values for the population. Note any test that was truncated to 5 % shear strain.

13.1.32 If transition strain is determined, the method of linear fit (if used) and the strain ranges over which the linear fit or chord lines were determined.

13.1.33 Individual values of transition strain (if applicable), and the average value, standard deviation, and coefficient of variation (in percent) for the population.

13.1.34 Failure mode and location of failure for each specimen.

13.2 The data reported with this test method include mechanical testing data, material identification data, and fiber, filler, and core material identification data, and shall be in accordance with Guides **E 1434**, **E 1309**, and **E 1471**, respectively. Each data item discussed is identified as belonging to one of the following categories: (VT) required for reporting of a valid test result, (VM) required for valid material traceability, (RT) recommended for maximum test method traceability, (RM) recommended for maximum material traceability, or (O) for optional data items. At a minimum, the report shall include all (VT) category items from Guide **E 1434**.

13.2.1 *Clarification of Guide E 1434 Responses for This Standard:*

13.2.1.1 *Field A1, Test Method*—The response shall be either “D 4255-95” or “D 4255M-95,” as appropriate.

13.2.1.2 *Field A5, Type of Test*—The response shall be “in-plane shear.”

13.2.1.3 *Field B2, Specimen Orientation*—The response shall be “0.0.”

13.2.1.4 *Block E, Transducer Block*—Used twice; once for each transducer.

13.2.1.5 *Block F, Specimen Geometry Block*—F6 (reinforcement volume) may be actual values, or they may be the nominal or average value for the sample. F9 (area) is the actual area.

13.2.1.6 *H32/K58, Progressive Damage Parameter*—The response shall be “0.2 % offset strength.”

14. Precision and Bias

14.1 *Precision*—The ASTM round-robin data indicates that the interlaboratory repeatability of an earlier version of the rail shear test procedure was low.⁸ However, round-robin data on this more detailed procedure are not yet available.

14.2 *Bias*—Bias cannot be determined for this test method as no acceptable reference standard exists.

15. Keywords

15.1 composite materials; shear modulus of elasticity; shear properties; shear strength

⁸ P. A. Lockwood, “Results of the ASTM Round Robin on the Rail Shear Test for Composites,” *Composites Technology Review*, Vol 3, No. 2, 1981, pp. 83–86.

ASTM International takes no position respecting the validity of any patent rights asserted in connection with any item mentioned in this standard. Users of this standard are expressly advised that determination of the validity of any such patent rights, and the risk of infringement of such rights, are entirely their own responsibility.

This standard is subject to revision at any time by the responsible technical committee and must be reviewed every five years and if not revised, either reapproved or withdrawn. Your comments are invited either for revision of this standard or for additional standards and should be addressed to ASTM International Headquarters. Your comments will receive careful consideration at a meeting of the responsible technical committee, which you may attend. If you feel that your comments have not received a fair hearing you should make your views known to the ASTM Committee on Standards, at the address shown below.

This standard is copyrighted by ASTM International, 100 Barr Harbor Drive, PO Box C700, West Conshohocken, PA 19428-2959, United States. Individual reprints (single or multiple copies) of this standard may be obtained by contacting ASTM at the above address or at 610-832-9585 (phone), 610-832-9555 (fax), or service@astm.org (e-mail); or through the ASTM website (www.astm.org).