



Standard Test Method for Measuring the Damage Resistance of a Fiber-Reinforced Polymer Matrix Composite to a Drop-Weight Impact Event¹

This standard is issued under the fixed designation D 7136/D 7136M; the number immediately following the designation indicates the year of original adoption or, in the case of revision, the year of last revision. A number in parentheses indicates the year of last reappraisal. A superscript epsilon (ε) indicates an editorial change since the last revision or reappraisal.

1. Scope

1.1 This test method determines the damage resistance of multidirectional polymer matrix composite laminated plates subjected to a drop-weight impact event. The composite material forms are limited to continuous-fiber reinforced polymer matrix composites, with the range of acceptable test laminates and thicknesses defined in 8.2.

1.2 A flat, rectangular composite plate is subjected to an out-of-plane, concentrated impact using a drop-weight device with a hemispherical impactor. The potential energy of the drop-weight, as defined by the mass and drop height of the impactor, is specified prior to test. Equipment and procedures are provided for optional measurement of contact force and velocity during the impact event. The damage resistance is quantified in terms of the resulting size and type of damage in the specimen.

1.3 The test method may be used to screen materials for damage resistance, or to inflict damage into a specimen for subsequent damage tolerance testing. When the impacted plate is tested in accordance with Test Method D 7137/D 7137M, the overall test sequence is commonly referred to as the Compression After Impact (CAI) method. Quasi-static indentation per Test Method D 6264 may be used as an alternate method of creating damage from an out-of-plane force and measuring damage resistance properties.

1.4 The damage resistance properties generated by this test method are highly dependent upon several factors, which include specimen geometry, layup, impactor geometry, impactor mass, impact force, impact energy, and boundary conditions. Thus, results are generally not scalable to other configurations, and are particular to the combination of geometric and physical conditions tested.

1.5 The values stated in either SI units or inch-pound units are to be regarded separately as standard. Within the text the inch-pound units are shown in brackets. The values stated in

each system are not exact equivalents; therefore, each system must be used independently of the other. Combining values from the two systems may result in nonconformance with the standard.

1.6 *This standard does not purport to address all of the safety concerns, if any, associated with its use. It is the responsibility of the user of this standard to establish appropriate safety and health practices and determine the applicability of regulatory limitations prior to use.*

2. Referenced Documents

2.1 *ASTM Standards:*²

- D 792 Test Methods for Density and Specific Gravity (Relative Density) of Plastics by Displacement
- D 883 Terminology Relating to Plastics
- D 3171 Test Methods for Constituent Content of Composite Materials
- D 3763 Test Method for High Speed Puncture Properties of Plastics using Load and Displacement Sensors
- D 3878 Terminology for Composite Materials
- D 5229/D 5229M Test Method for Moisture Absorption Properties and Equilibrium Conditioning of Polymer Matrix Composite Laminates
- D 5687/D 5687M Guide for Preparation of Flat Composite Panels with Processing Guidelines for Specimen Preparation
- D 6264 Test Method for Measuring the Damage Resistance of a Fiber-Reinforced Polymer-Matrix Composite to a Concentrated Quasi-Static Indentation Force
- D 7137/D 7137M Test Method for Compressive Residual Strength Properties of Damaged Polymer Matrix Composite Plates
- E 4 Practices for Force Verification of Testing Machines
- E 6 Terminology Relating to Methods of Mechanical Testing
- E 18 Test Methods for Rockwell Hardness and Rockwell

¹ This test method is under the jurisdiction of ASTM Committee D30 on Composite Materials and is the direct responsibility of Subcommittee D30.05 on Structural Test Methods.

Current edition approved Oct. 1, 2007. Published November 2007. Originally approved in 2005. Last previous edition approved in 2005 as D 7136/D 7136M - 05^{ε1}.

² For referenced ASTM standards, visit the ASTM website, www.astm.org, or contact ASTM Customer Service at service@astm.org. For *Annual Book of ASTM Standards* volume information, refer to the standard's Document Summary page on the ASTM website.

Superficial Hardness of Metallic Materials

E 122 Practice for Calculation of Sample Size to Estimate, with a Specified Tolerable Error, the Average of Characteristic for a Lot or Process

E 177 Practice for Use of the Terms Precision and Bias in ASTM Test Methods

E 456 Terminology Relating to Quality and Statistics

E 1309 Guide for Identification of Fiber-Reinforced Polymer Matrix Composite Materials in Databases

E 1434 Guide for Recording Mechanical Test Data of Fiber-Reinforced Composite Materials in Databases

2.2 Military Standards:

MIL-HDBK-17-3F Composite Materials Handbook, Volume 3—Polymer Matrix Composites Materials Usage, Design and Analysis³

MIL-HDBK-728/1 Nondestructive Testing⁴

MIL-HDBK-731A Nondestructive Testing Methods of Composite Materials—Thermography⁴

MIL-HDBK-732A Nondestructive Testing Methods of Composite Materials—Acoustic Emission⁴

MIL-HDBK-733A Nondestructive Testing Methods of Composite Materials—Radiography⁴

MIL-HDBK-787A Nondestructive Testing Methods of Composite Materials—Ultrasonics⁴

NASA Reference Publication 1092 Standard Tests for Toughened Resin Composites, Revised Edition, July 1983⁵

3. Terminology

3.1 *Definitions*—Terminology **D 3878** defines terms relating to composite materials. Terminology **D 883** defines terms relating to plastics. Terminology **E 6** defines terms relating to mechanical testing. Terminology **E 456** and Practice **E 177** define terms relating to statistics. In the event of a conflict between terms, Terminology **D 3878** shall have precedence over the other standards.

3.2 *Definitions of Terms Specific to This Standard*—If the term represents a physical quantity, its analytical dimensions are stated immediately following the term (or letter symbol) in fundamental dimension form, using the following ASTM standard symbology for fundamental dimensions, shown within square brackets: $[M]$ for mass, $[L]$ for length, $[T]$ for time, $[\theta]$ for thermodynamic temperature, and $[nd]$ for non-dimensional quantities. Use of these symbols is restricted to analytical dimensions when used with square brackets, as the symbols may have other definitions when used without the brackets.

3.2.1 *dent depth, d $[L]$, n* —residual depth of the depression formed by an impactor after the impact event. The dent depth shall be defined as the maximum distance in a direction normal

to the face of the specimen from the lowest point in the dent to the plane of the impacted surface that is undisturbed by the dent.

3.2.2 *nominal value, n* —a value, existing in name only, assigned to a measurable property for the purpose of convenient designation. Tolerances may be applied to a nominal value to define an acceptable range for the property.

3.2.3 *principal material coordinate system, n* —a coordinate system with axes that are normal to the planes of symmetry inherent to a material.

3.2.3.1 *Discussion*—Common usage, at least for Cartesian axes (123 , xyz , and so forth), generally assigns the coordinate system axes to the normal directions of planes of symmetry in order that the highest property value in a normal direction (for elastic properties, the axis of greatest stiffness) would be 1 or x , and the lowest (if applicable) would be 3 or z . Anisotropic materials do not have a principal material coordinate system due to the total lack of symmetry, while, for isotropic materials, any coordinate system is a principal material coordinate system. In laminated composites, the principal material coordinate system has meaning only with respect to an individual orthotropic lamina. The related term for laminated composites is “reference coordinate system.”

3.2.4 *recorded contact force, F $[MLT^{-2}]$, n* —the force exerted by the impactor on the specimen during the impact event, as recorded by a force indicator.

3.2.5 *reference coordinate system, n* —a coordinate system for laminated composites used to define ply orientations. One of the reference coordinate system axes (normally the Cartesian x -axis) is designated the reference axis, assigned a position, and the ply principal axis of each ply in the laminate is referenced relative to the reference axis to define the ply orientation for that ply.

3.2.6 *striker tip, n* —the portion or component of the impactor which comes into contact with the test specimen first during the impact event.

3.3 Symbols:

A = cross-sectional area of a specimen

C_E = specified ratio of impact energy to specimen thickness

CV = coefficient of variation statistic of a sample population for a given property (in percent)

D = damage diameter (see Fig. 11)

d = dent depth

E = potential energy of impactor prior to drop

E_1 = absorbed energy at the time at which force versus time curve has a discontinuity in force or slope

E_a = energy absorbed by the specimen during the impact event

E_i = actual impact energy (incident kinetic energy)

E_{max} = absorbed energy at the time of maximum recorded contact force

F = recorded contact force

F_1 = recorded contact force at which the force versus time curve has a discontinuity in force or slope

F_{max} = maximum recorded contact force

g = acceleration due to gravity

h = specimen thickness

H = impactor drop height

³ Available from U.S. Army Research Laboratory, Materials Directorate, Aberdeen Proving Ground, MD 21001.

⁴ Available from U.S. Army Materials Technology Laboratory, Watertown, MA 02471.

⁵ Available from National Aeronautics and Space Administration (NASA)-Langley Research Center, Hampton, VA 23681-2199.

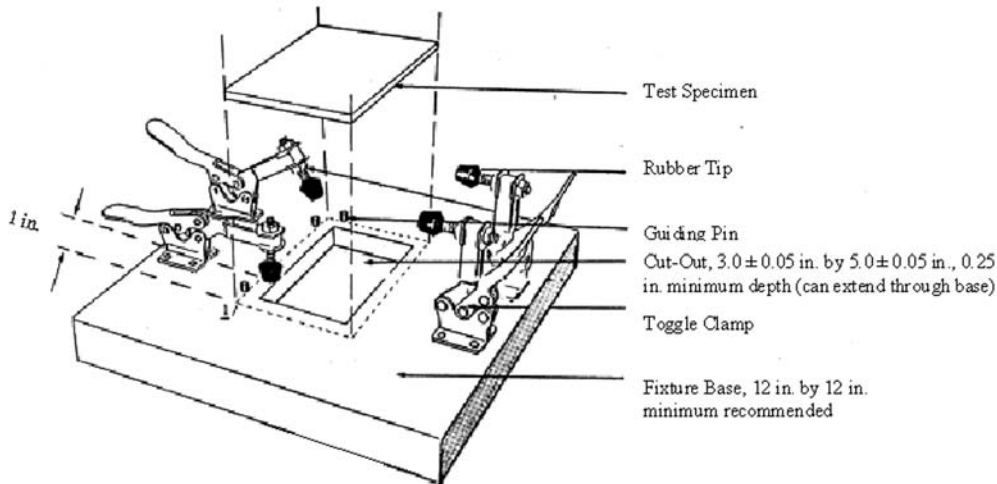

NOTE—Clamp tip centered 0.25 in. from edge of cut-out.

FIG. 1 Impact Support Fixture (Inch-Pound Version)

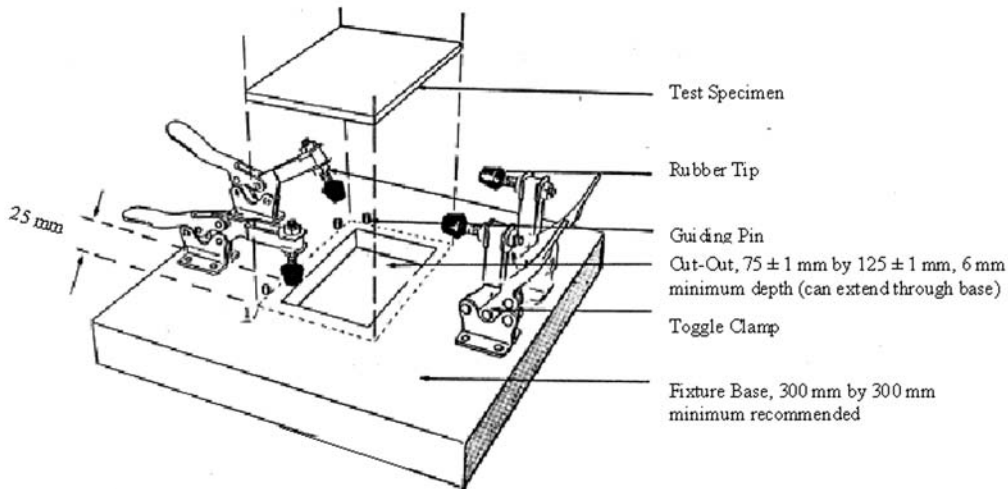

NOTE—Clamp tip centered 6 mm from edge of cut-out.

FIG. 2 Impact Support Fixture (SI Version)

- l = specimen length
- m = impactor mass
- m_d = impactor mass for drop height calculation
- m_{dlbm} = impactor mass in standard gravity for drop height calculation
- n = number of specimens per sample population
- N = number of plies in laminate under test
- S_{n-1} = standard deviation statistic of a sample population for a given property
- t = time during impactor drop and impact event
- t_i = time of initial contact
- t_T = contact duration (total duration of the impact event)
- w = specimen width
- v = impactor velocity
- v_i = impactor velocity at time of initial contact, t_i
- W_{12} = distance between leading edges of the two flag prongs on velocity indicator
- x_i = test result for an individual specimen from the sample population for a given property

- \bar{x} = mean or average (estimate of mean) of a sample population for a given property
- δ = impactor displacement

4. Summary of Test Method

- 4.1 A drop-weight impact test is performed using a balanced, symmetric laminated plate. Damage is imparted through out-of-plane, concentrated impact (perpendicular to the plane of the laminated plate) using a drop weight with a hemispherical striker tip. The damage resistance is quantified in terms of the resulting size and type of damage in the specimen. The damage response is a function of the test configuration; comparisons cannot be made between materials unless identical test configurations, test conditions, and so forth are used.
- 4.2 Optional procedures for recording impact velocity and applied contact force versus time history data are provided.
- 4.3 Preferred damage states resulting from the impact are located in the center of the plate, sufficiently far from the plate

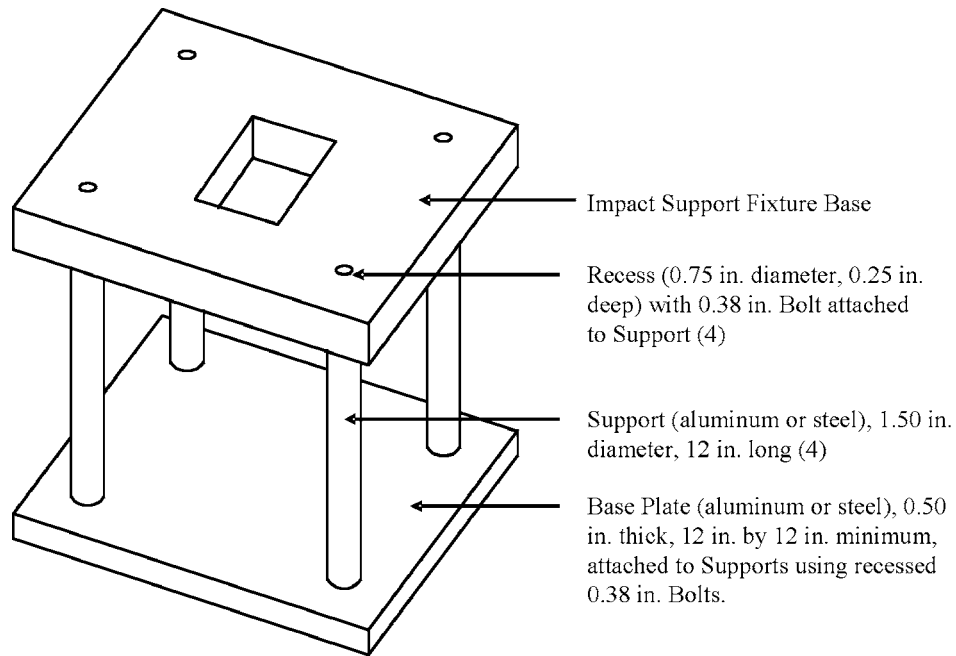

FIG. 3 Representative Rigid Base (Inch-Pound Version)

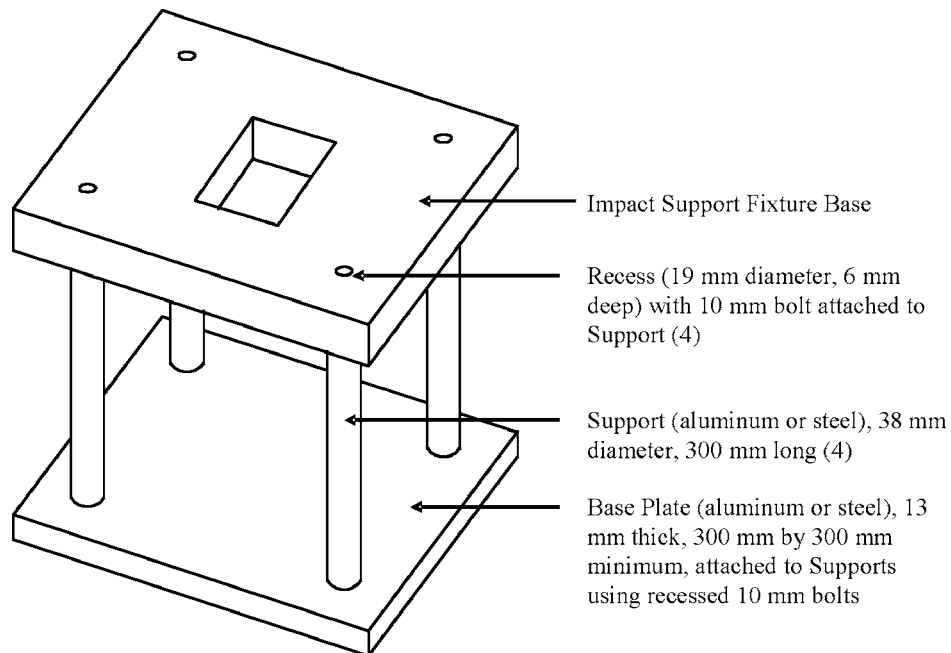

FIG. 4 Representative Rigid Base (SI Version)

edges such that the local states of stress at the edges and at the impact location do not interact during the damage formation event.

5. Significance and Use

5.1 Susceptibility to damage from concentrated out-of-plane impact forces is one of the major design concerns of many structures made of advanced composite laminates. Knowledge of the damage resistance properties of a laminated composite plate is useful for product development and material selection.

5.2 Drop-weight impact testing can serve the following purposes:

5.2.1 To establish quantitatively the effects of stacking sequence, fiber surface treatment, variations in fiber volume fraction, and processing and environmental variables on the damage resistance of a particular composite laminate to a concentrated drop-weight impact force or energy.

5.2.2 To compare quantitatively the relative values of the damage resistance parameters for composite materials with different constituents. The damage response parameters can include dent depth, damage dimensions, and through-thickness locations, F_1 , F_{max} , E_1 and E_{max} , as well as the force versus time curve.

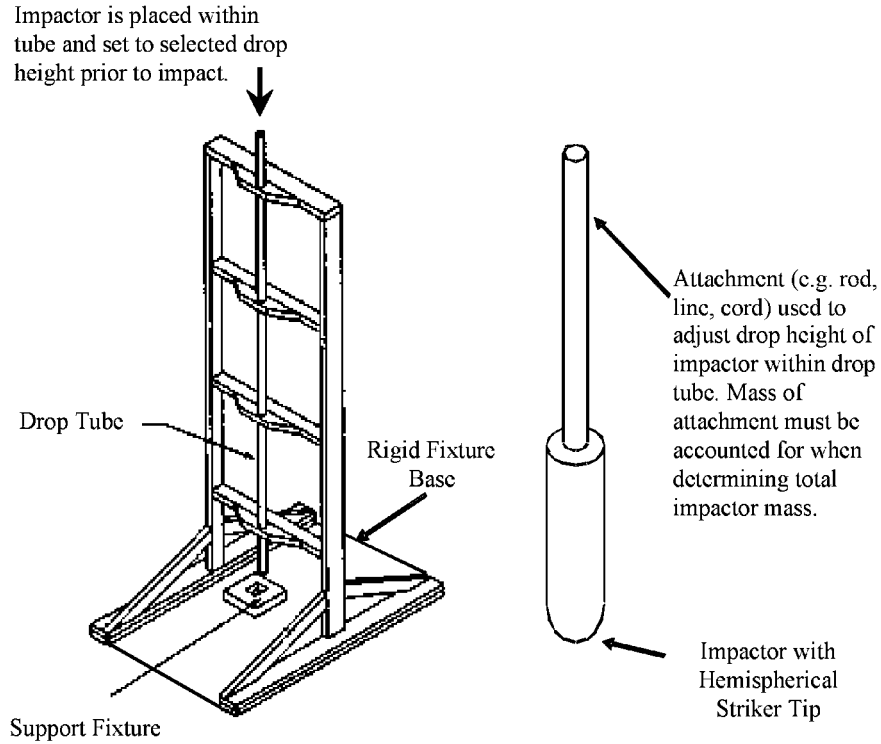

FIG. 5 Impact Device with Cylindrical Tube Impactor Guide Mechanism

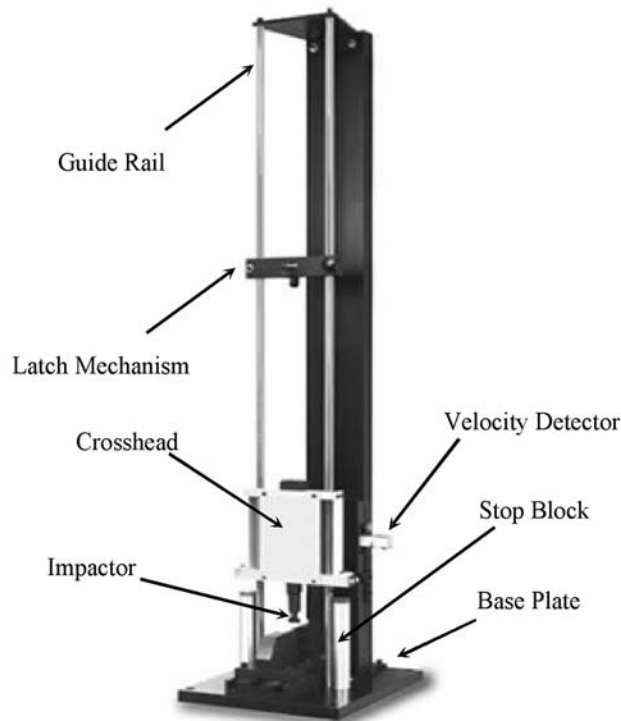

FIG. 6 Impact Device with Double Column Impactor Guide Mechanism

5.2.3 To impart damage in a specimen for subsequent damage tolerance tests, such as Test Method [D 7137/D 7137M](#).

5.3 The properties obtained using this test method can provide guidance in regard to the anticipated damage resistance

capability of composite structures of similar material, thickness, stacking sequence, and so forth. However, it must be understood that the damage resistance of a composite structure is highly dependent upon several factors including geometry,

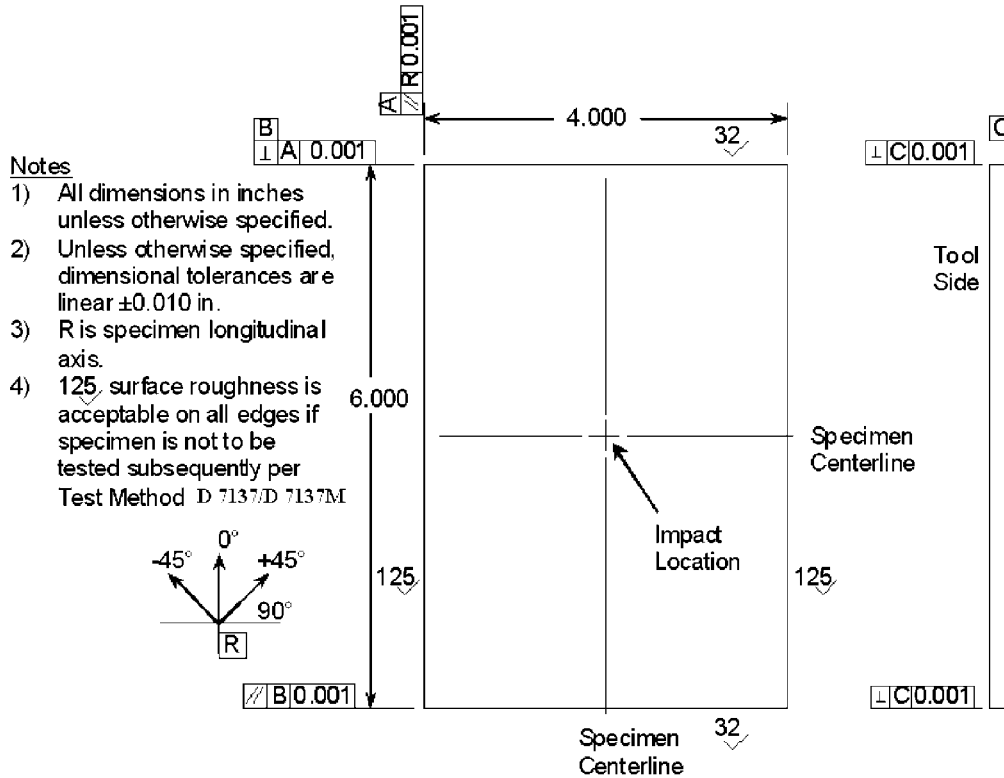

FIG. 7 Drop-Weight Impact Test Specimen (Inch-Pound Version)

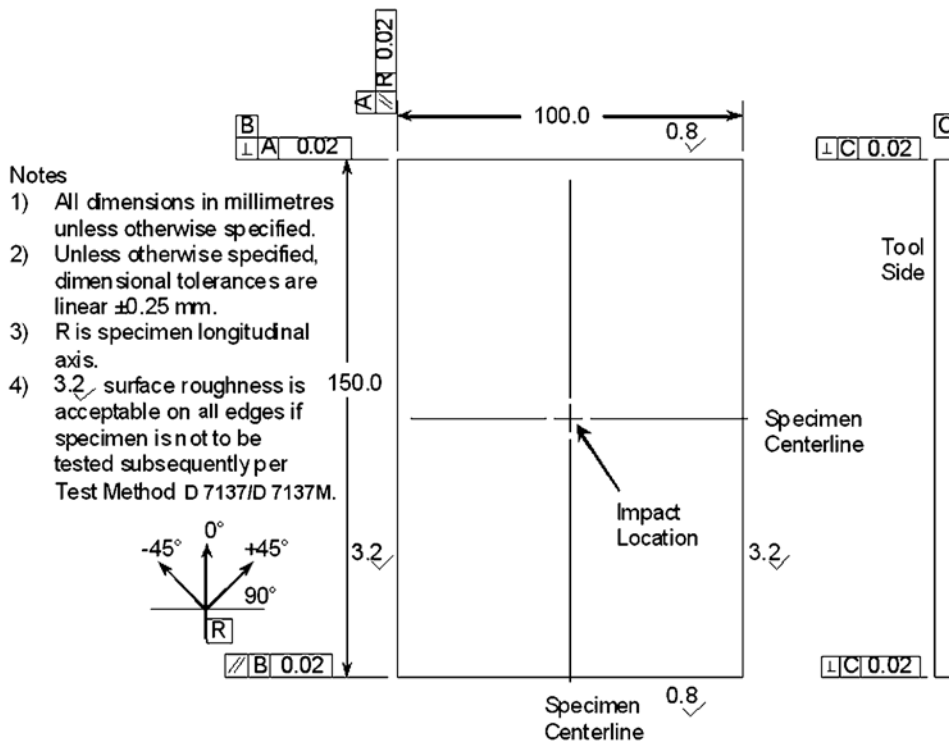

FIG. 8 Drop-Weight Impact Test Specimen (SI Version)

thickness, stiffness, mass, support conditions, and so forth. Significant differences in the relationships between impact force/energy and the resultant damage state can result due to

differences in these parameters. For example, properties obtained using this test method would more likely reflect the damage resistance characteristics of an unstiffened monolithic

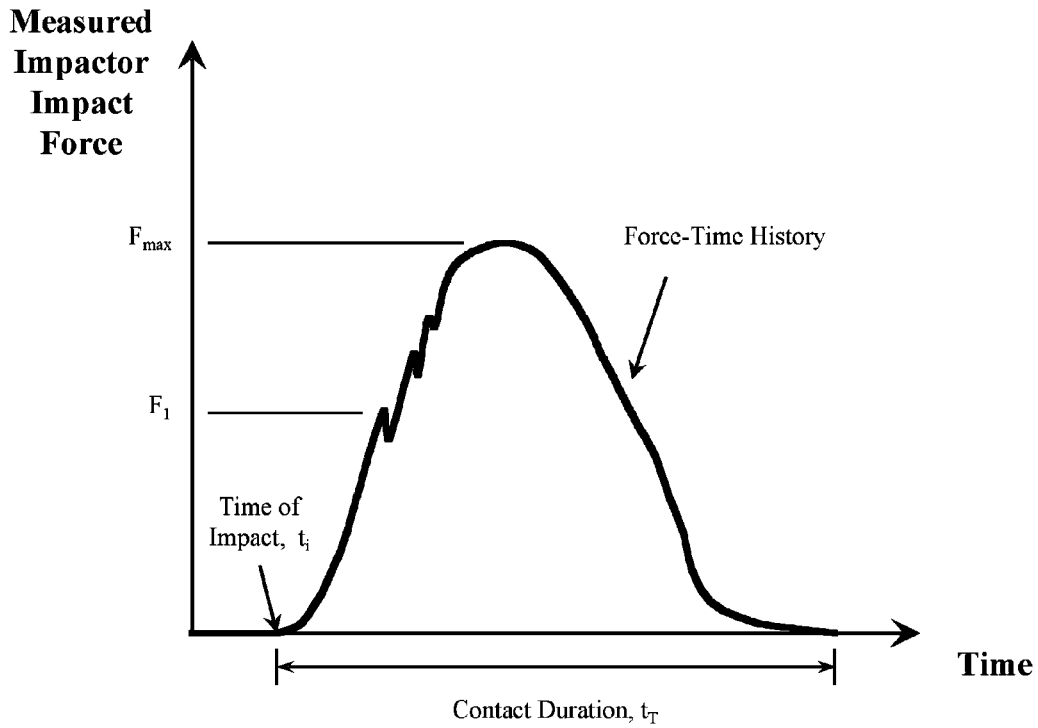

FIG. 9 Representative Impactor Force versus Time History

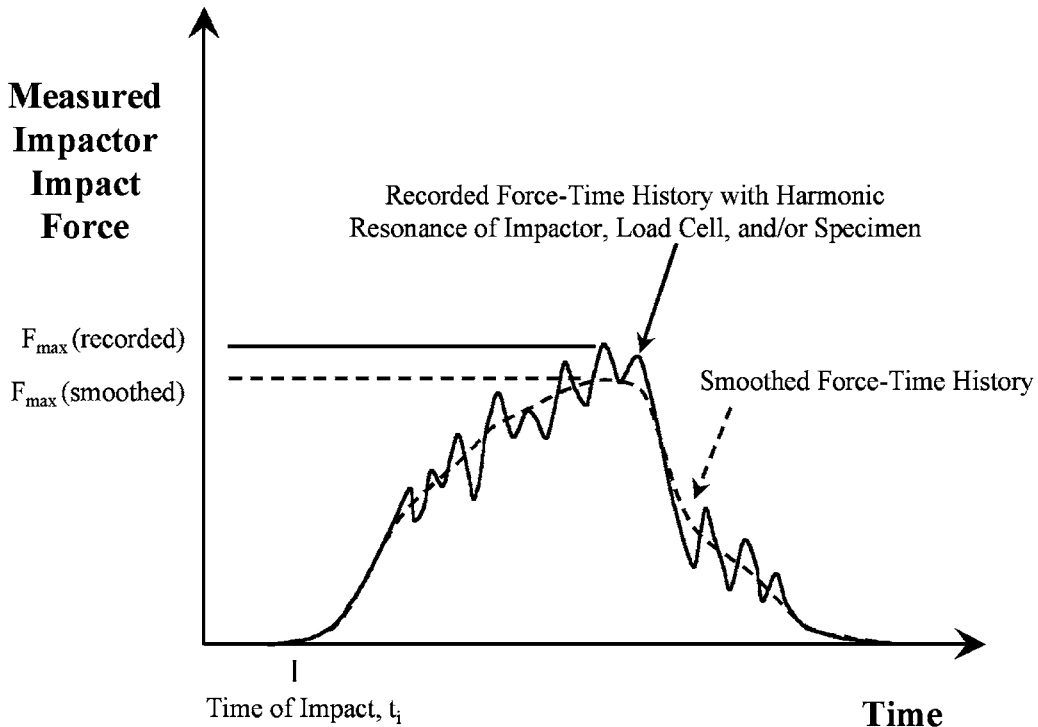

FIG. 10 Impactor Force versus Time History with Harmonic Resonance

skin or web than that of a skin attached to substructure which resists out-of-plane deformation. Similarly, test specimen properties would be expected to be similar to those of a panel with equivalent length and width dimensions, in comparison to those of a panel significantly larger than the test specimen,

which tends to divert a greater proportion of the impact energy into elastic deformation.

5.4 The standard impactor geometry has a blunt, hemispherical striker tip. Historically, for the standard laminate configuration and impact energy, this impactor geometry has

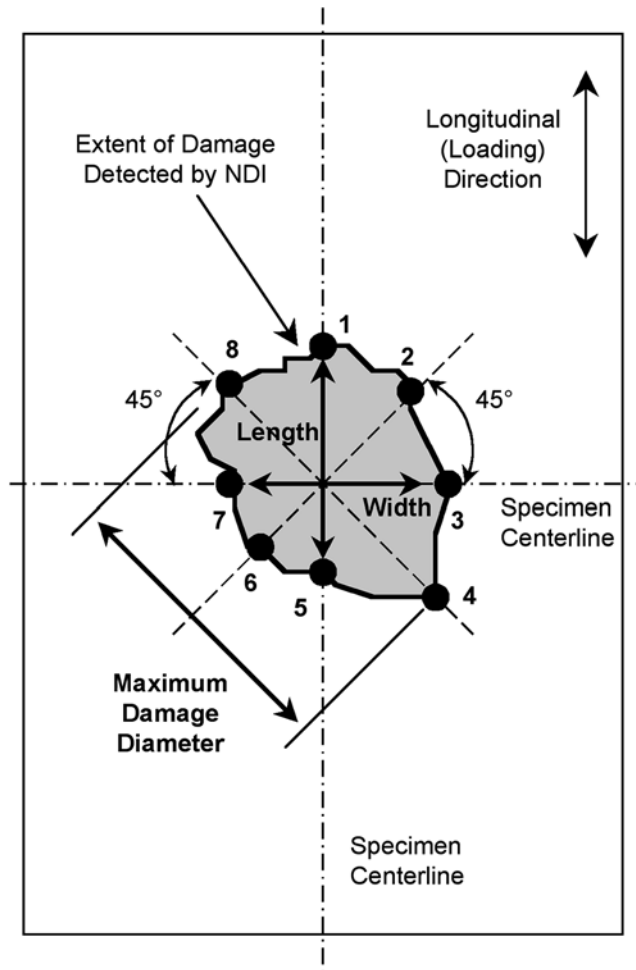

FIG. 11 Measurement of Extent of Damage

generated a larger amount of internal damage for a given amount of external damage, when compared with that observed for similar impacts using sharp striker tips.

5.5 The standard test utilizes a constant impact energy normalized by specimen thickness, as defined in 13.1. Some testing organizations may desire to use this test method in conjunction with D 7137/D 7137M to assess the compressive residual strength of specimens containing a specific damage state, such as a defined dent depth, damage geometry, and so forth. In this case, the testing organization should subject several specimens, or a large panel, to multiple low velocity impacts at various impact energy levels using this test method. A relationship between impact energy and the desired damage parameter can then be developed. Subsequent drop weight impact and compressive residual strength tests can then be performed using specimens impacted at an interpolated energy level that is expected to produce the desired damage state.

6. Interferences

6.1 The response of a laminated plate specimen to out-of-plane drop-weight impact is dependent upon many factors, such as laminate thickness, ply thickness, stacking sequence, environment, geometry, impactor mass, striker tip geometry, impact velocity, impact energy, and boundary conditions.

Consequently, comparisons cannot be made between materials unless identical test configurations, test conditions, and laminate configurations are used. Therefore, all deviations from the standard test configuration shall be reported in the results.

6.2 *Material and Specimen Preparation*—Poor material fabrication practices, lack of control of fiber alignment, and damage induced by improper specimen machining are known causes of high material data scatter in composites in general. Important aspects of plate specimen preparation that contribute to data scatter include thickness variation, out-of-plane curvature, surface roughness, and failure to maintain the dimensions specified in 8.2.

6.3 *Specimen Geometry and Impact Location*—The size, shape, thickness, and stacking sequence of the plate, along with the impact location, can affect the impact deformation and damage formation behavior of the specimens significantly. The degree of laminate orthotropy can strongly affect the damage formation. Results can be affected if the impact force is not applied perpendicular to the plane of the laminated plate.

6.4 *Support Fixture Characteristics*—Results are affected by the support fixture cut-out dimensions, material, fixture bending rigidity, and the rigidity of the surface that the support fixture is located upon. The location of the clamps, clamp

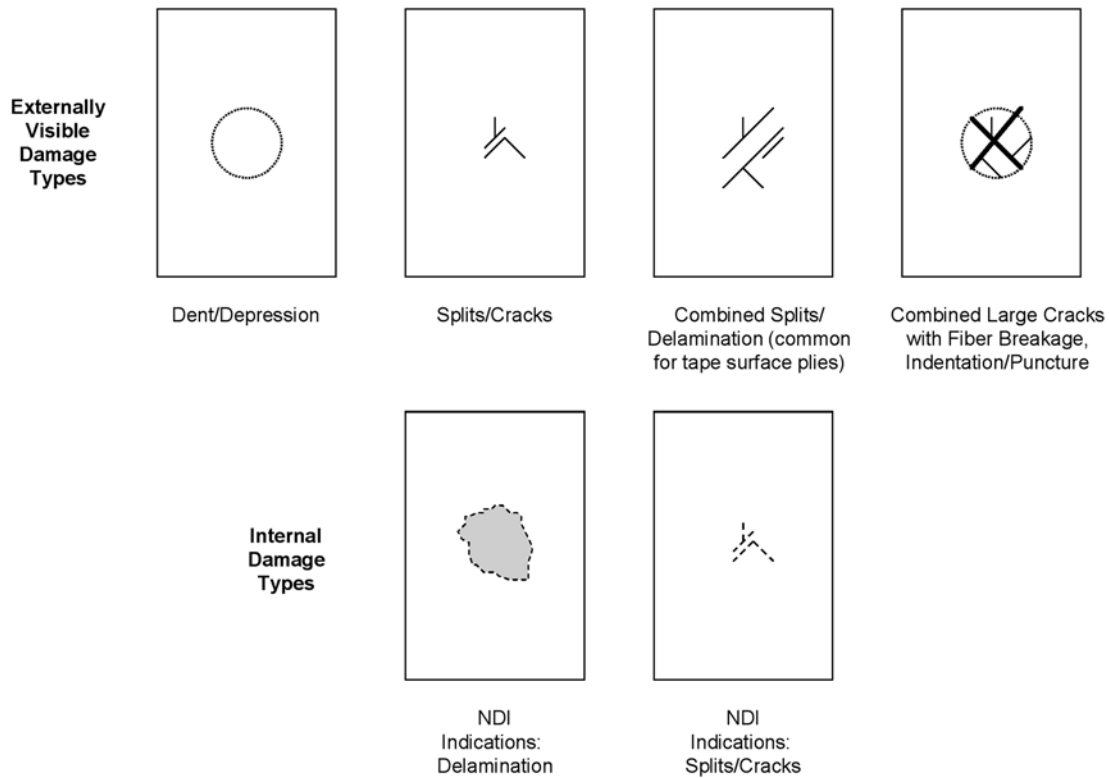

FIG. 12 Commonly Observed Damage Modes from Out-of-Plane Drop-Weight Impact

geometry, and the clamping force can affect the deformation of the specimen during impact.

6.5 *Impact Device Characteristics*—Results are affected by the rigidity of the impact device, friction between the impactor and guide(s) during the drop, impactor geometry, and impactor mass. Errors can result if the test specimen and specimen support fixture are not centered with respect to the impact device.

6.6 *Force Oscillations*—Force versus time histories typically contain many oscillations which may be introduced by two primary sources. The first source is the natural frequency (or frequencies) of the impactor, and is often referred to as “impactor ringing.” The ringing may be more severe if the impactor components are not rigidly attached. The second source of force oscillations is the flexural vibration of the impacted specimen. The “ringing” oscillations generally occur at higher frequencies than the oscillations generated by the specimen. The high-frequency ringing oscillations do not typically represent an actual force transmitted to the specimen. However, the oscillations caused by specimen motion are actual forces applied to the specimen and should not be filtered or smoothed. For both sources, the oscillations are typically excited during initial contact and during damage formation. For further definition and examples of force oscillations, refer to Appendix X1 of Test Method D 3763.

6.7 *Impact Variables*—Results are affected by differences in the drop height, impact velocity, and impact energy. Results are also affected by wave propagation and vibrations in the specimen, impactor, impact device and support fixture during the impact event.

6.8 *Non-Destructive Inspection*—Non-destructive inspection (NDI) results are affected by the particular method utilized, the inherent variability of the NDI method, the experience of the operator, and so forth.

6.9 Force F_1 and absorbed energy E_1 do not physically represent the initiation of damage, as sub-critical matrix cracks and small delaminations may initiate at lower force and energy values. Rather, F_1 and E_1 represent the initial value of force and energy at which a change in the stiffness characteristics of the specimen can be detected, respectively.

6.10 The dent depth may “relax” or reduce with time or upon exposure to different environmental conditions.

6.11 Non-laminated, 3-D fiber-reinforced composites may form damage through different mechanisms than laminates.

7. Apparatus

7.1 *Micrometers and Calipers*—The micrometer(s) shall be used for specimen length, width and thickness measurements, and shall use a 4 to 6 mm [0.16 to 0.25 in.] nominal diameter ball-interface on irregular surfaces such as the bag-side of a laminate, and a flat anvil interface on machined edges or very smooth tooled surfaces. A caliper of suitable size shall be used for measurement of dimensions for detected damage. The accuracy of the instruments shall be suitable for reading to within 1 % of the specimen width and thickness. For typical specimen geometries, an instrument with an accuracy of ± 0.0025 mm [± 0.0001 in.] or better is desirable for thickness measurement, while an instrument with an accuracy of ± 0.025 mm [± 0.001 in.] or better is desirable for length, width, and damage dimension measurement.

NOTE 1—Calipers may be used for specimen length and width measurements if the specimen is not intended to undergo subsequent compression residual strength testing in accordance with Test Method **D 7137/D 7137M**. For specimens intended to undergo subsequent residual strength testing, specimen length and width measurements shall use micrometers to ensure consistent measurement accuracy for both test methods.

7.2 Support Fixture—The impact support fixture, shown in **Figs. 1 and 2**, shall utilize a plate at least 20 mm [0.75 in.] thick constructed from either aluminum or steel. The cut-out in the plate shall be 75 ± 1 mm by 125 ± 1 mm [3.0 ± 0.05 in. by 5.0 ± 0.05 in.]. The face of the plate shall be flat to within 0.1 mm [0.005 in.] in the area which contacts the test specimen. Guiding pins shall be located such that the specimen shall be centrally positioned over the cut-out. Four clamps shall be used to restrain the specimen during impact. The clamps shall have a minimum holding capacity of 1100 N (200 lbf). The tips of the clamps shall be made of neoprene rubber with a durometer of 70-80 Shore A. The fixture shall be aligned to a rigid base using bolts or clamps; a representative base design is shown in **Figs. 3 and 4**.

NOTE 2—When impacted with the standard impactor (defined in **7.3.1**) at the standard energy level defined in **11.7.1**, the standard specimen has historically developed damage sizes less than half of the unsupported specimen width (38 mm [1.5 in.]). Should the expected damage area exceed this size (such as in studies for barely visible impact damage, for example), it is recommended to examine alternative specimen and fixture designs, such as **NASA 1092**, which are larger and can accommodate larger damage areas without significant interaction from edge support conditions.

7.3 Impact Device—Representative drop-weight impact testing devices are shown in **Figs. 5 and 6**. At a minimum, the impact device shall include a rigid base, a drop-weight impactor, a rebound catcher and a guide mechanism. The rebound catcher is typically an inertially activated latch that trips upon the initial impact, then catches the impactor on a stop during its second decent. The rebound catcher must not affect the motion of the impactor until after the impactor has lost contact with the specimen after the initial impact. If such equipment is unavailable, rebound hits may be prevented by sliding a piece of rigid material (wood, metal, and so forth) between the impactor and specimen, after the impactor rebounds from the specimen surface after impact. More complex devices may include latching and hoist mechanisms, stop blocks or shock absorbers, and instrumentation for determining impactor velocity and impact force. The use of velocity and force instrumentation is recommended to provide additional information about the impact event, but is not required.

7.3.1 Impactor—The impactor shall have a mass of 5.5 ± 0.25 kg [12 ± 0.5 lbm], and shall have a smooth hemispherical striker tip with a diameter of 16 ± 0.1 mm [0.625 ± 0.005 in.] and a hardness of 60 to 62 HRC as specified in Test Methods **E 18**. If a different impactor is used as part of the testing, the shape, dimensions and mass shall be noted and the results reported as non-standard.

NOTE 3—If the desired impact energy level cannot be achieved using the standard impactor mass dropped from a height of at least 300 mm [12 in.], an impactor with a mass of 2.0 ± 0.25 kg [4 ± 0.5 lbm] shall be used instead.

7.3.2 Guide Mechanism—Historical guide mechanisms include single cylindrical tubes through which a cylindrical impactor travels (**Fig. 5**), as well as double-column guides for a crosshead-mounted impactor (**Fig. 6**). The height of the guide mechanism shall be sufficient to permit drop-weight testing for the impact desired energy level. For cylindrical drop tubes, the clearance between the impactor and tube inner diameter should not exceed 1 mm [0.03 in.]. Details of the guide mechanism geometry shall be noted. In all respects, guide friction shall be negligible; otherwise, velocity measurements shall be required and impact energy calculations shall be based upon the measured velocity (Eq 4).

7.3.3 Force Indicator—If utilized, the force indicator shall be in conformance with Practices **E 4** and Test Method **D 3763**, and shall be capable of indicating the impact force imparted to the test specimen. This device shall be essentially free from inertia-lag at the predicted impact velocity and shall indicate the force with an accuracy over the force range(s) of interest to within $\pm 1\%$ of the indicated value. The force indicator shall be positioned such that at least 95 % of the impactor mass is located above it; the error in the force reading increases as the percentage of mass located above the load cell decreases.

7.3.4 Velocity Indicator—The impact device may be instrumented to measure the velocity of the impactor at a given point before impact, such that the impact velocity may be calculated. Commonly, such systems use a double-pronged flag, which obstruct a light beam between a photo-diode emitter and detector. The leading edges of the flag prongs are typically separated by 3.0 to 10.0 mm [0.125 to 0.400 in.]. The flag prongs shall be positioned such that velocity measurement is completed between 3 to 6 mm [0.13 to 0.25 in.] vertically above the surface of the specimen. The impact velocity is calculated using the measured time the light beam is obstructed by each prong, as well as the time that an impact force is first detected. Velocity measurement shall be accurate to within 5 mm/s [0.20 in./s].

7.4 Conditioning Chamber—When conditioning materials at non-laboratory environments, a temperature-/vapor-level controlled environmental conditioning chamber is required that shall be capable of maintaining the required temperature to within $\pm 3^\circ\text{C}$ [$\pm 5^\circ\text{F}$] and the required relative humidity level to within $\pm 3\%$. Chamber conditions shall be monitored either on an automated continuous basis or on a manual basis at regular intervals.

7.5 Environmental Test Chamber—An environmental test chamber is required for test environments other than ambient testing laboratory conditions. This chamber shall be capable of maintaining the test specimen at the required test environment during the mechanical test. The test temperature shall be maintained within $\pm 3^\circ\text{C}$ [$\pm 5^\circ\text{F}$] of the required temperature, and the relative humidity level shall be maintained to within $\pm 3\%$ of the required humidity level.

7.6 Data Acquisition Equipment—For simple drop-weight impact testing, no data acquisition equipment is required. Equipment capable of recording force and velocity data is required if those measurements are desired. If utilized, such equipment shall be in accordance with Annex A1, Minimum Instrumentation Requirements, of Test Method **D 3763**. The

natural frequency of the transducer-impactor assembly shall be greater than 6 kHz, the analog-to-digital converter shall be 8-bit or greater, the minimum sampling rate shall be 100 kHz, and the data storage capacity shall be 1000 points or larger.

7.7 Dent Depth Indicator—The dent depth can be measured using a dial depth gage, a depth gage micrometer, a tripod-mounted depth gage, or a properly calibrated displacement transducer. The measuring probe shall have a spherical tip with a maximum radius of curvature of 8.0 mm (0.35 in.). An instrument with an accuracy of $\pm 25 \mu\text{m}$ [± 0.001 in.] is desirable for depth measurement.

7.8 Balance or Weighing Scale—An analytical balance or weighing scale is required that is capable of measuring the impactor mass accurately to $\pm 0.5\%$.

8. Sampling and Test Specimens

8.1 Sampling—Test at least five specimens per test condition unless valid results can be gained through the use of fewer specimens, as in the case of a designed experiment. For statistically significant data the procedures outlined in Practice E 122 should be consulted. The method of sampling shall be reported.

8.2 Geometry:

8.2.1 Stacking Sequence—For comparison screening of the drop-weight impact damage resistance of different materials, the standard specimen thickness shall be 4.0 to 6.0 mm [0.16 to 0.24 in.] with a target thickness of 5.0 mm [0.20 in.] and the laminate defined as follows:

8.2.1.1 Unidirectional Tape—Laminate construction shall consist of the appropriate number of unidirectional plies to achieve a total cured thickness nearest to 5.0 mm [0.20 in.] with a stacking sequence of $[45/0/-45/90]_{NS}$ where N is a whole number. If the “nearest” thickness is less than 4.0 mm [0.16 in.], the next value of N shall be used (N+1). Recommended layups for various nominal cured ply thicknesses are provided in Table 1. The laminated plate layup is to be defined such that the 0° fiber orientation is aligned with the lengthwise (long) dimension.

8.2.1.2 Woven Fabric—Laminate construction shall consist of the appropriate number of fabric plies to achieve a total cured thickness nearest to 5.0 mm [0.20 in.] with a stacking sequence of $[(+45/-45)/(0/90)]_{NS}$ where N is a whole number. If the “nearest” thickness is less than 4.0 mm [0.16 in.], the next value of N shall be used (N+1). The designations (+45/-45) and (0/90) represent a single layer of woven fabric with the warp and weft fibers oriented at the specified angles. Fabric laminates containing satin-type weaves shall have symmetric warp surfaces, unless otherwise specified and noted

in the report. Recommended layups for various nominal cured ply thicknesses are provided in Table 2. The laminated plate layup is to be defined such that the 0° fiber orientation is aligned with the lengthwise (long) dimension.

8.2.1.3 Alternative Stacking Sequences—Laminates fabricated using other layups or fiber orientations, or both, may be evaluated for drop-weight impact damage resistance using this test method. Tests conducted using alternative stacking sequences must be designated as such, with the stacking sequence recorded and reported with any test results.

8.2.2 Specimen Configuration—The geometry of the plate specimen is shown in Figs. 7 and 8.

NOTE 4—It is permissible to impact a panel larger than the specified dimensions, then to cut out specimens (with the impact site centered) for subsequent residual strength testing in accordance with Test Method D 7137/D 7137M, as long as the panel dimensions and procedures utilized are recorded as a variation to the test method. Impacting a larger panel can help relieve interaction between the edge conditions and the damage creation mechanisms.

8.3 Specimen Preparation—Guide D 5687/D 5687M provides recommended specimen preparation practices and should be followed where practical.

8.3.1 Panel Fabrication—Control of fiber alignment is critical. Improper fiber alignment will affect the measured properties. Erratic fiber alignment will also increase the coefficient of variation. Report the panel fabrication method. Specimens shall be of uniform cross-section over the entire surface and shall not have a thickness taper greater than 0.08 mm [0.003 in.] in any direction across the length and width of the specimen. The coefficient of variation for thickness measurements taken in 11.2.5 should be less than 2%.

8.3.2 Machining Methods—Specimen preparation is extremely important for this specimen. Take precautions when cutting specimens from large panels to avoid notches, undercuts, rough or uneven surfaces, or delaminations due to inappropriate machining methods. Obtain final dimensions by water-lubricated precision sawing, milling, or grinding. The use of diamond-tipped tooling (as well as water-jet cutting) has been found to be extremely effective for many material systems. Edges should be flat and parallel within the specified tolerances. Machining tolerances and surface finish requirements are as noted in Figs. 7 and 8. Record and report the specimen cutting methods.

TABLE 1 Recommended Layups for Various Nominal Cured Ply Thicknesses, Unidirectional Tape

Nominal Cured Ply Thickness		Ply Count	Layup
Minimum, mm [in.]	Maximum, mm [in.]		
0.085 [0.0033]	0.10 [0.004]	48	$[45/0/-45/90]_{6S}$
0.10 [0.004]	0.13 [0.005]	40	$[45/0/-45/90]_{5S}$
0.13 [0.005]	0.18 [0.007]	32	$[45/0/-45/90]_{4S}$
0.18 [0.007]	0.25 [0.010]	24	$[45/0/-45/90]_{3S}$
0.25 [0.010]	0.50 [0.020]	16	$[45/0/-45/90]_{2S}$
0.50 [0.020]	0.75 [0.030]	8	$[45/0/-45/90]_S$

TABLE 2 Recommended Layups for Various Nominal Cured Ply Thicknesses, Woven Fabric

Nominal Cured Ply Thickness		Ply Count	Layup
Minimum, mm [in.]	Maximum, mm [in.]		
0.085 [0.0033]	0.10 [0.004]	48	$[(45/-45)/(0/90)]_{12S}$
0.10 [0.004]	0.13 [0.005]	40	$[(45/-45)/(0/90)]_{10S}$
0.13 [0.005]	0.15 [0.006]	32	$[(45/-45)/(0/90)]_{8S}$
0.15 [0.006]	0.18 [0.007]	28	$[(45/-45)/(0/90)]_{7S}$
0.18 [0.007]	0.20 [0.008]	24	$[(45/-45)/(0/90)]_{6S}$
0.20 [0.008]	0.25 [0.010]	20	$[(45/-45)/(0/90)]_{5S}$
0.25 [0.010]	0.36 [0.014]	16	$[(45/-45)/(0/90)]_{4S}$
0.36 [0.014]	0.50 [0.020]	12	$[(45/-45)/(0/90)]_{3S}$
0.50 [0.020]	1.00 [0.040]	8	$[(45/-45)/(0/90)]_{2S}$
1.00 [0.040]	1.50 [0.060]	4	$[(45/-45)/(0/90)]_S$

8.3.3 *Labeling*—Label the plate specimens so that they will be distinct from each other and traceable back to the raw material, and will neither influence the test nor be affected by it.

9. Calibration

9.1 The accuracy of all measuring equipment shall have certified calibrations that are current at the time of use of the equipment.

10. Conditioning

10.1 The recommended pre-test condition is effective moisture equilibrium at a specific relative humidity as established by Test Method [D 5229/D 5229M](#), however, if the test requestor does not explicitly specify a pre-test conditioning environment, no conditioning is required and the test specimens may be tested as prepared.

10.2 The pre-test specimen conditioning process, to include specified environmental exposure levels and resulting moisture content, shall be reported with the test data.

NOTE 5—The term “moisture”, as used in Test Method [D 5229/D 5229M](#), includes not only the vapor of a liquid and its condensate, but the liquid itself in large quantities, as for immersion.

10.3 If no explicit conditioning process is performed the specimen conditioning process shall be reported as “unconditioned” and the moisture content as “unknown”.

11. Procedure

11.1 *Parameters to be Specified Prior to Test:*

11.1.1 The specimen sampling method, specimen type and geometry, and conditioning travelers (if required).

11.1.2 The damage resistance properties and data reporting format desired.

NOTE 6—Determine specific material property, accuracy, and data reporting requirements prior to test for proper selection of instrumentation and data recording equipment. Estimate the specimen damage resistance to aid in transducer selection, calibration of equipment, and determination of equipment settings.

11.1.3 The environmental conditioning test parameters.

11.1.4 Diameter of striker tip and mass of impactor.

11.1.5 Nominal impact energy and drop height.

11.1.6 If impact velocity is to be determined, predicted impact velocity and detector settings (for example, height of detector above test specimen, distance between leading edges of flag prongs).

11.1.7 If performed, sampling method, plate specimen geometry, and test parameters used to determine density and reinforcement volume.

11.2 *General Instructions:*

11.2.1 Report any deviations from this test method, whether intentional or inadvertent.

11.2.2 If specific gravity, density, reinforcement volume, or void volume are to be reported, then obtain these samples from the same panels being tested. Specific gravity and density may be evaluated by means of Test Method [D 792](#). Volume percent of the constituents may be evaluated by one of the procedures of Test Methods [D 3171](#).

11.2.3 Following final specimen machining, but before conditioning, perform a baseline non-destructive inspection of the specimen to detect flaws or defects which may exist prior to impact testing. A variety of NDI techniques are available for detecting both surface and interior flaws in composites. Visual inspection and liquid penetrant methods can be used for identifying surface defects, while more sophisticated techniques are required for detecting internal flaws such as cracks, splits and delaminations. These techniques include ultrasonics, radiography, thermography, acoustic emission, modal analysis (such as instrumented tap testing) and eddy-current testing. An overview of available techniques is provided in section 7.4.2 of [MIL-HDBK-17-3F](#). Basic principles and procedures for these methods are covered in the [MIL-HDBK-728/1](#) series, while more specific information on the theory and interpretation of data can be found in [MIL-HDBK-731A](#) for thermography, [MIL-HDBK-732A](#) for acoustic emission, [MIL-HDBK-733A](#) for radiography, and [MIL-HDBK-787A](#) for ultrasonics. Record the method(s), specification(s) and parameters used in the NDI evaluation(s).

NOTE 7—The NDI techniques discussed in [MIL-HDBK-17-3F](#) each have particular attributes in regard to sensitivity to different damage types, ability to detect different types of damage in three dimensions, and so forth. It may be necessary to utilize a combination of NDI techniques to properly characterize the three-dimensional damage state in some instances (for example, when multiple-layer delaminations and matrix cracks are present).

11.2.4 Condition the specimens as required. Store the specimens in the conditioned environment until test time, if the test environment is different than the conditioning environment.

11.2.5 Following final specimen machining and any conditioning, but before all testing, measure the specimen width, w , and length, l , at two locations in the vicinity of the location to be damaged. The thickness of the specimen shall be measured at four locations near the impact location, and recorded as the average of the four measurements. The accuracy of all measurements shall be within 1 % of the dimension. Record the dimensions to three significant figures in units of millimetres [inches].

11.3 *Test Environment*—If possible, test the specimen under the same fluid exposure level used for conditioning. However, cases such as elevated temperature testing of a moist specimen place unrealistic requirements on the capabilities of common environmental chambers. In such cases the mechanical test environment may need to be modified, for example, by testing at elevated temperature with no fluid exposure control, but with a specified limit on time to test after withdrawal from the conditioning chamber. Record any modifications to the test environment.

NOTE 8—When testing a conditioned specimen at elevated temperature with no fluid exposure control, the percentage moisture loss of the specimen prior to test completion may be estimated by placing a conditioned traveler coupon of known weight within the test chamber at the same time the specimen is placed in the chamber. Upon completion of the test, the traveler coupon is removed from the chamber, weighed, and the percentage weight calculated and reported.

11.4 *Impactor Preparation*—Prepare the impactor by attaching the hemispherical striker tip and adding required mass. If the mass of the impactor (or any component(s) of the

impactor) is unknown or uncertain, weigh the impactor (or component(s)) to a precision of $\pm 0.5\%$ using the balance or weighing scale. Mount the impactor in the impact device, and prepare force measurement instrumentation as required. All of the components must be rigidly attached to each other, to minimize resonance during the impact event.

11.5 Specimen Installation—Place the specimen in the support fixture, ensuring the specimen is centered relative to the cut-out. Unless otherwise specified, impact the tool side of the specimen. Secure the specimen in place using the four rubber-tipped clamps (applying minimal clamping force such that the clamp tips barely touch the specimen) to prevent the specimen from rebounding during the impact event. The clamp tips should be positioned approximately 25 mm [1.0 in.] from the specimen edges.

11.6 Velocity Indicator—If utilized, position the velocity detector at a point such that the velocity measurement is completed between 3 to 6 mm [0.13 to 0.25 in.] vertically above the surface of the specimen.

11.7 Drop Height:

11.7.1 Impact Energy and Drop Height Calculations—Calculate the impact energy as defined in 13.1 and the drop height as defined in 13.2.

11.7.2 Raise Impactor—Position the impactor at the calculated drop height.

11.8 Impact—Drop the impactor to impact the specimen once without a rebound impact.

NOTE 9—Some impact devices may utilize mechanisms to automatically prevent rebound hits. If such equipment is unavailable, this may be done by sliding a piece of rigid material (wood, metal, and so forth) between the impactor and specimen, after the impactor rebounds from the specimen surface after impact.

11.9 Data Recording—If instrumentation is utilized, record force versus time data during contact continuously or at frequent regular intervals; for this test method, a sampling rate of 100 kHz and a target minimum of 100 data points per test are recommended. Record the time at which the velocity indicator light beam is interrupted by each of the flag prongs.

11.9.1 Examples of recorded contact force versus time curves are shown in Figs. 9 and 10. The onset of specimen-impactor contact is noted by the detection of a non-zero contact force. As the impactor presses into the specimen, it will flex the specimen and form a local depression as the contact force increases. Sharp drops in recorded contact force indicate damage processes that result in a sudden loss of stiffness in the contact region.

NOTE 10—Rapid increases and decreases in recorded contact force response with time, shown in Fig. 10, can result from harmonic resonance of the impactor, load cell or specimen during the impact event. Significant resonance can make determination of the F_1 force and E_1 energy difficult. For material forms such as plastics, post-test digital smoothing is often utilized to understand the effective peak force and absorbed energy in such instances. For composite materials, however, the oscillations in the force response most often reflect actual forces applied to the specimen and should not be smoothed out. The use of digital post-processing can also “smooth out” sharp drops in the impact response curve. If smoothing is used in data interpretation, both the recorded data and the post-processed “smoothed” data shall be reported, along with a description of the

post-processing algorithm. Additional information on interpreting data from impact force data may be found in Appendix X1 of Test Method D 3763.

11.9.2 Parameters which can be determined from the contact force versus time curve(s) after the test include the F_1 force (recorded contact force at which the force versus time curve has a discontinuity in force or slope), the maximum contact force F_{max} , absorbed energy E_1 (at F_1 force), absorbed energy E_{max} (at maximum contact force), and contact duration t_T .

11.10 Dent Depth—Measure the dent depth, as defined in 3.2.1, using a suitable dent depth indicator as defined in 7.7. The dent shall be measured immediately after the specimen is impacted. If distances are measured relative to a fixed point, the dent depth will be the difference between the lowest point in the dent and the plate surface. The distance to the plane of the specimen’s surface shall be the average of four measurements spaced 90° apart and at least 25 mm [1.0 in.] from the impact point to provide a sufficient distance away from the dent to not influence the measurement. If the depth is measured directly using a depth gage, the depth shall be the average of two measurements with the gage rotated 90° between measurements. The base of the depth gage shall be at least 50 mm [2.0 in.] and sufficiently large to span over the region affected by the dent. These requirements also apply if the depth is measured using a tripod-mounted depth gage (one which bases its reference surface on a micrometer holder that touches the surface at three points on a prescribed diameter). The dent depth shall be measured to the nearest 0.03 mm [0.001 in.].

11.11 Dent Relaxation—Over time, or under environmental exposure, the dent depth may decrease due to relaxation of the composite material. If information on short term dent relaxation is desired, measure the dent depth 7 days after impacting as in 11.10. Record the dent depth, the time duration after impacting that the measurement was taken, and the environmental conditions prior to measurement.

11.12 Non-Destructive Inspection:

11.12.1 Evaluate the extent of damage caused by the impact event using non-destructive inspection (NDI) techniques. Utilize NDI method(s), specification(s), and parameters consistent with those used to evaluate the specimen prior to impact in 11.2.3. Record the method(s), specification(s), and parameters used in the NDI evaluation(s).

11.12.2 Measure and record geometric dimensions for the detected damage, using a suitable instrument as defined in 7.1. Using Fig. 11 as a guide, determine locations of the eight indicated points relative to the center of the specimen. Also determine the damage width, damage length, and maximum damage diameter. Alternative measurement locations may be required to characterize the extent of damage for non-standard layups or fiber orientations, or both. Alternatively, automated algorithms may be used to define the extent of damage and to calculate the two-dimensional damage area using digital NDI data.

NOTE 11—Dimensional tolerances for the measured damage width, length and diameter are dependent upon the NDI method(s) utilized.

11.12.3 Record the damage mode(s) observed for each specimen, and the surface(s) on which the damage modes are

observed. More than one damage mode may be present in a damaged specimen. Fig. 12 illustrates commonly observed damage modes.

12. Validation

12.1 Property values shall not be calculated for any specimen that forms damage or breaks at some obvious flaw, unless such flaw constitutes a variable being studied. Retests shall be performed for any specimen on which values are not calculated.

12.2 If a significant number of specimens in a sample population exhibit damage originating or extending significantly away from the impact location, the impact support conditions shall be re-examined. Factors considered should include fixture alignment, impactor guide tube alignment, gaps between the specimen and restraints, and specimen thickness taper.

13. Calculation

13.1 *Impact Energy*—Calculate the impact energy level using Eq 1 unless otherwise specified. Record the impact energy level to three significant figures.

$$E = C_E h \quad (1)$$

where:

E = potential energy of impactor prior to drop, J [in.-lbf],
 C_E = specified ratio of impact energy to specimen thickness, 6.7 J/mm [1500 in.-lbf/in], and
 h = nominal thickness of specimen, mm [in.].

13.2 *Drop Height*—Calculate the drop height required to produce the specified impact energy, and record the drop height to three significant figures. Utilize Eq 2 when using SI units and Eq 3 when using inch-pound units.

$$H = \frac{E}{m_d g} \quad (2)$$

where:

H = drop-height of impactor, m,
 m_d = mass of impactor for drop height calculation, kg, and
 g = acceleration due to gravity, 9.81 m/s².

$$H = \frac{E}{m_{dlbm} g} \quad (3)$$

where:

H = drop-height of impactor, in., and
 m_{dlbm} = mass of impactor in standard gravity for drop height calculation, lbm.

NOTE 12—The selected impactor mass must permit a minimum drop height of 300 mm [12 in.].

NOTE 13—The pound mass is defined such that one pound force imparts an acceleration of 32.17 ft/s² to it. In standard gravity, one pound force is numerically the same as one pound mass, so it is not necessary to include the term for gravitational acceleration in the inch-pound version of the equation.

13.3 *Impact Velocity*—If the impact device is capable of detecting the velocity of the impactor, calculate the impact velocity using Eq 4 and report the results to three significant figures. This calculation is performed automatically by most systems with velocity detection capability, but may be performed manually using the indicated timing data if necessary.

$$v_i = \frac{(W_{12})}{(t_2 - t_1)} + g \left(t_i - \frac{(t_1 + t_2)}{2} \right) \quad (4)$$

where:

v_i = impact velocity, m/s [in./s],
 W_{12} = distance between leading edges of the first (lower) and second (upper) flag prongs, m [in.],
 t_1 = time first (lower) flag prong passes detector,
 t_2 = time second (upper) flag prong passes detector, and
 t_i = time of initial contact obtained from force versus time curve, s.

13.4 *Measured Impact Energy*—If the impact device is capable of detecting the velocity of the impactor, calculate the actual impact energy using Eq 5 and report the results to three significant figures. This calculation is performed automatically by most systems with velocity detection capability, but may be performed manually if necessary. The measured impact energy may differ from the nominal impact energy calculated in 13.1 due to friction losses during the drop.

$$E_i = \frac{m v_i^2}{2} \quad (5)$$

where:

E_i = measured impact energy, J [in.-lbf], and
 m = mass of impactor, kg [lbm].

13.5 *Statistics*—Calculate the average value, standard deviation, and coefficient of variation (in percent) for d for each series of tests. If the impact device is capable of detecting the contact force and velocity of the impactor, also perform such calculations for impact velocity, impact energy, F_1 , F_{max} , E_1 , E_{max} and t_T for each series of tests:

$$\bar{x} = \left(\sum_{i=1}^n x_i \right) / n \quad (6)$$

$$S_{n-1} = \sqrt{\left(\sum_{i=1}^n x_i^2 - n \bar{x}^2 \right) / (n - 1)} \quad (7)$$

$$CV = 100 \times S_{n-1} / \bar{x} \quad (8)$$

where:

\bar{x} = sample mean (average),
 S_{n-1} = sample standard deviation,
 CV = sample coefficient of variation, %,
 n = number of specimens, and
 x_i = measured or derived property.

13.6 *Velocity versus Time*—If the impact device is monitoring contact force, generate a curve of nominal velocity versus time using Eq 9 and numerical integration of the force versus time data. A positive velocity value represents downward motion. Common numerical integration algorithms used in this application include the trapezoidal rule and Simpson's rule (2 and 3 point Newton-Cotes formulas, respectively).⁶ The time step of the numerical integration must be equal to the time step (inverse of the frequency) of data sampling.

$$v(t) = v_i + g t - \int_0^t \frac{F(t)}{m} dt \quad (9)$$

⁶ Whittaker, E. T., and Robinson, G., "The Calculus of Observations: A Treatise on Numerical Mathematics," 4th ed., New York: Dover, 1967, pp. 156-158.

where:

- v = impactor velocity at time t , m/s [in./s],
- t = time during test, in which $t = 0$ is the time when the impactor initially contacts the specimen, s, and
- F = measured impactor contact force at time t , N [lbf].

13.7 *Impactor Displacement versus Time*—If the impact device is monitoring contact force, generate a curve of impactor displacement versus time using Eq 10 and numerical integration of the force versus time data. A positive displacement value represents downward displacement from the drop height.

$$\delta(t) = \delta_i + v_i t + \frac{g t^2}{2} - \int_0^t \left(\int_0^t \frac{F(t)}{m} dt \right) dt \quad (10)$$

where:

- δ = impactor displacement at time t , m [in.], and
- δ_i = impactor displacement from reference location at time $t = 0$, m [in.].

13.8 *Absorbed Energy versus Time*—If the impact device is monitoring contact force, generate a curve of energy absorbed by the specimen versus time using Eq 11.

$$E_a(t) = \frac{m(v_i^2 - v(t)^2)}{2} + m g \delta(t) \quad (11)$$

where:

- E_a = absorbed energy at time t , J [in.-lbf].

14. Report

14.1 Report the following information, or references pointing to other documentation containing this information, to the maximum extent applicable (reporting of items beyond the control of a given testing laboratory, such as might occur with material details or panel fabrication parameters, shall be the responsibility of the requestor):

NOTE 14—Guides E 1309 and E 1434 contain data reporting recommendations for composite materials and composite materials mechanical testing.

- 14.1.1 The revision level or date of issue of this test method.
- 14.1.2 The name(s) of the test operator(s).
- 14.1.3 Any variations to this test method, anomalies noticed during testing, or equipment problems occurring during testing.
- 14.1.4 Identification of all the applicable constituent information, including: material specification, material type, manufacturer's material designation, manufacturer's batch or lot number, source (if not from manufacturer), date of certification, expiration of certification, filament diameter, tow or yarn filament count and twist, sizing, form or weave, fiber areal weight, matrix type, matrix content, and volatiles content.
- 14.1.5 Description of the fabrication steps used to prepare the parent laminate including: fabrication start date, fabrication end date, process specification, cure cycle, consolidation method, and a description of the equipment used.
- 14.1.6 Ply orientation and stacking sequence of the laminate, relative to the longitudinal (long) dimension.
- 14.1.7 If requested, report density, volume percent reinforcement, and void content test methods, specimen sampling method and geometries, test parameters, and test results.

14.1.8 Method of preparing the test specimen, including specimen labeling scheme and method, specimen geometry, sampling method, and specimen cutting method.

14.1.9 Calibration dates and methods for all measurements and test equipment.

14.1.10 Type and configuration of test machine, data acquisition equipment, data sampling rate.

14.1.11 If applicable, type of velocity detector and key parameters (for example, height of detector above test specimen, distance between leading edges of flag prongs), type of force detector.

14.1.12 Measured length, width and thickness for each specimen (prior to and after damage and conditioning, if appropriate).

14.1.13 Weight of specimen, type of balance or weighing scale, and measurement accuracy.

14.1.14 Conditioning parameters and results.

14.1.15 Relative humidity and temperature of the testing laboratory.

14.1.16 Environment of the test machine environmental chamber (if used) and soak time at environment.

14.1.17 Number of specimens tested.

14.1.18 Diameter of hemispherical impactor striker tip.

14.1.19 Total mass of impactor.

14.1.20 Nominal impact energy and drop height.

14.1.21 Results of nondestructive evaluation tests, including method, specification, inspection parameters and operator, both before and after impact.

14.1.22 Damage geometry, including positions of the eight specified measurement points, damage width, damage length, maximum damage diameter, damage area (if calculated), and through-thickness location.

14.1.23 Damage modes observed for each specimen.

14.1.24 Individual dent depths, along with average value, standard deviation, and coefficient of variation (in percent) for the population.

14.1.25 If dent relaxation is evaluated, individual dent depths after relaxation, along with the time duration after impacting and the environmental conditions prior to measurement.

14.1.26 Individual values of F_1 , F_{max} , E_1 and E_{max} , if these parameters were measured, along with average value, standard deviation, and coefficient of variation (in percent) for the population.

14.1.27 Contact force versus time history data for each specimen so evaluated.

14.1.28 Impact velocity and actual impact energy for each specimen so evaluated, along with average value, standard deviation, and coefficient of variation (in percent) for the population.

14.1.29 Contact duration for each specimen so evaluated, along with average value, standard deviation, and coefficient of variation (in percent) for the population.

14.1.30 Velocity, impactor displacement and absorbed energy versus time histories for each specimen so evaluated, along with method of numerical integration utilized.

15. Precision and Bias

15.1 *Precision*—The data required for the development of a precision statement is not available for this test method. Committee D30 is currently planning a round-robin test series for this test method in order to determine precision.

15.2 *Bias*—Bias cannot be determined for this test method as no acceptable reference standard exists.

16. Keywords

16.1 composite materials; damage resistance; drop-weight impact; impact testing

ASTM International takes no position respecting the validity of any patent rights asserted in connection with any item mentioned in this standard. Users of this standard are expressly advised that determination of the validity of any such patent rights, and the risk of infringement of such rights, are entirely their own responsibility.

This standard is subject to revision at any time by the responsible technical committee and must be reviewed every five years and if not revised, either reapproved or withdrawn. Your comments are invited either for revision of this standard or for additional standards and should be addressed to ASTM International Headquarters. Your comments will receive careful consideration at a meeting of the responsible technical committee, which you may attend. If you feel that your comments have not received a fair hearing you should make your views known to the ASTM Committee on Standards, at the address shown below.

This standard is copyrighted by ASTM International, 100 Barr Harbor Drive, PO Box C700, West Conshohocken, PA 19428-2959, United States. Individual reprints (single or multiple copies) of this standard may be obtained by contacting ASTM at the above address or at 610-832-9585 (phone), 610-832-9555 (fax), or service@astm.org (e-mail); or through the ASTM website (www.astm.org).